



# Climate-Smart Agriculture in Chad

## Climate-smart agriculture (CSA) considerations

**P** The agricultural sector occupies a dominant position in the national economy; it drives Chad's economic development, despite the country's entry into the ranks of oil-producing and exporting countries.

**A** Water management practices such as half-moon, zai pits, and water-spreading weirs, have a key role in adapting to climate risks in Chad. They aim at addressing the shortage of water during drought and dry spells. Crop and soil management practices are also found in the country aiming at improving soil fertility and moisture.

**M** The agricultural sub-sector contributes up to 66% of Chad's greenhouse gas emissions. The National Plan for Development for Farming (2017-2021) aims to reduce emissions through the sustainable management of pastures and water for livestock according to climatic zones and the selection of animal breeds.

**I** Through community radio broadcasts, the National Meteorology Agency provides agricultural sector actors with weather reports, early warning services, and climate information, including sowing dates.

**I** Climate-smart agriculture is not yet explicitly written into political and institutional priorities in Chad, although some current intervention targets address climate change. Chad is committed to this direction through its Nationally Determined Contributions..

**\$** International funds from multilateral financial institutions, Arab countries, and bilateral cooperation programs are available for climate change adaptation measures and for strengthening the organizational and operational capacities of institutions to meet their respective missions.

**P** Chad's climate is characterized by episodes of drought and variability in precipitation. Future predictions show an increase of temperature as well as of extreme events, such as droughts and floods. The impacts on agriculture will be very significant given that most subsistence crops and some cash crops are rain-fed. Significant changes in precipitation will heavily and directly affect Chadians.

**P** In a changing climate, the use of adapted or improved crop varieties with shorter growth cycles is advantageous, but limited seed availability constrains farmers' access to such varieties.

**M** Chad stores more greenhouse gases than it generates. However, the country is reducing its greenhouse gas emissions by prohibiting wood fuel and the manufacturing of wood charcoal and introducing a subsidy for gas consumption.

**I** The National Investment Plan for the Rural Sector in Chad (2016-2022) considers the major strategic issues and challenges for the Chadian government as it aims to build Chad's agro-sylvo-pastoral potential in order to resolve food deficits and ensure food and nutritional security at the national level.

**I** Chad does not have detailed, reliable, available, or consistent agricultural data. Developing a detailed and coherent agriculture database will facilitate the formulation, management, and monitoring of agricultural development plans and projects in the country.

**I** Potential funding sources for climate-smart agriculture in Chad exist. However, changes in sectoral and national policies, their improved coherence, and the development of the National Adaptation Plan could attract more funding.

**A** Adaptation    **M** Mitigation    **P** Productivity    **I** Institutions    **\$** Finance

Climate-smart agriculture (CSA) is oriented towards integrating agricultural development with climate change response. It aims to achieve food security and support broader developmental goals in the context of climate change and increasing food demand. CSA initiatives sustainably boost productivity, improve resilience, and reduce or eliminate greenhouse gases (GHGs); they require planning to address the trade-offs and synergies between the pillars of productivity, adaptation, and mitigation [1]. CSA initiatives consider the priorities of different countries and stakeholders to achieve more effective, efficient, and equitable food systems that

respond to environmental, social, and economic challenges in productive landscapes. Although the concept of CSA is new and still evolving, many of its practices already exist across the globe and are used by farmers to deal with various production risks [2]. The integration of CSA requires a critical inventory of current and promising practices for the future as well as the institutional, political, and financial factors that foster its adoption. This country profile provides an overview of the development baseline created to initiate discussion, both nationally and globally, on entry points for investing in CSA at scale.



# National context

## Economic relevance of agriculture

The agricultural sector is the mainstay of the Chadian economy, even after nearly two decades of oil extraction. Given the country's significant potential in terms of arable land and livestock, the agricultural sector accounts for almost 46% of Chad's average gross domestic product (GDP) as of 2019 and employs 77% of the labor force [3, 4] (Figure 1). Several agricultural sub-sectors in Chad have a competitive development potential in their regional and continental contexts. Exports of agricultural products averaged US\$78 million per year between 2015 and 2018 [5]. However, the agricultural sector underperforms due to poor soils, climatic hazards, conflicts, a lack of infrastructure, and limited access to quality seeds and fertilizers. These factors limit its ability to reduce its food deficit and guarantee food security [6]. As a result, Chad is highly dependent on the import of products like maize and sorghum. Between 2012 and 2016, maize accounted for 1% and sorghum for 4% of imports on average [5]. Nevertheless, the Chadian agricultural sector can develop and feed its population.

**Figure 1. Economic relevance of agriculture in Chad**

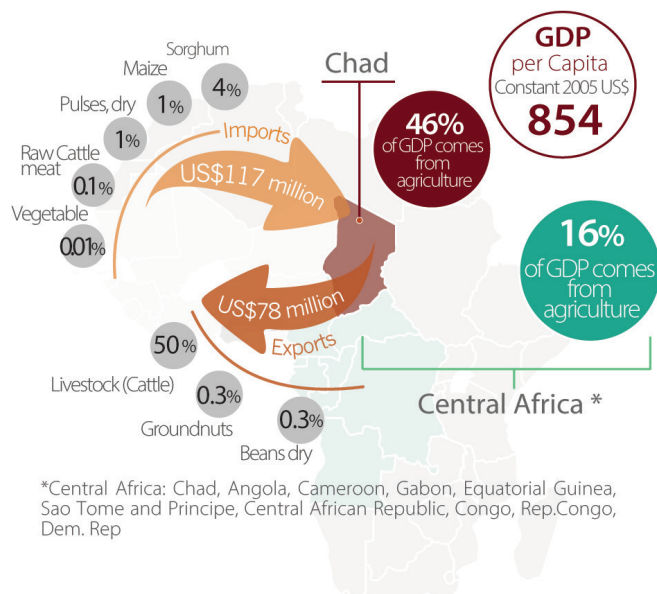

In 2019, the Chadian population was estimated at 15 million [3] (Figure 2). Demographic growth in the country stands at about 3.6% per year; at the current rate, the population will double every 20 years. Moreover, one in two Chadians is under the age of 15, and people under the age of 25 comprise 68% of the total population [7]. The gender inequality index is 0.7, indicating pervasive inequality in women's empowerment, including their access to reproductive healthcare and the labor market [8].

Chad has made progress in the fight against poverty: its

national poverty rate fell from 55% to 47% between 2003 and 2011. In 2018, 42% of the population lived below the national poverty line [3].

Access to basic services is low. While 57% of Chadians have access to drinking water, only 10% have access to electricity [9, 3]. In 2016, the literacy rate among youths aged 15 to 24 was estimated at 40% [3].

About 77% of the labor force works in agriculture; women account for 45% of the agricultural workforce [4]. These women represent, on average, 37% of all rural agricultural landowners [10]. The average equivalent of per capita income over the past five years in the agricultural sector is USD 1,545.78 [3].

**Figure 2. People, agriculture and livelihoods in Chad**

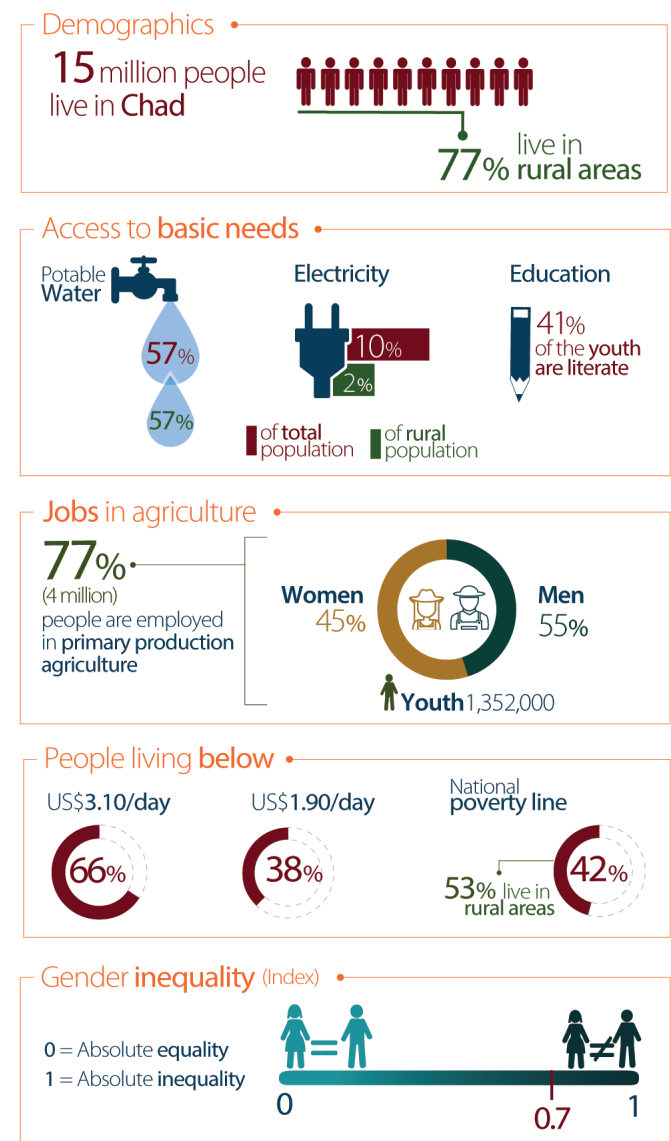

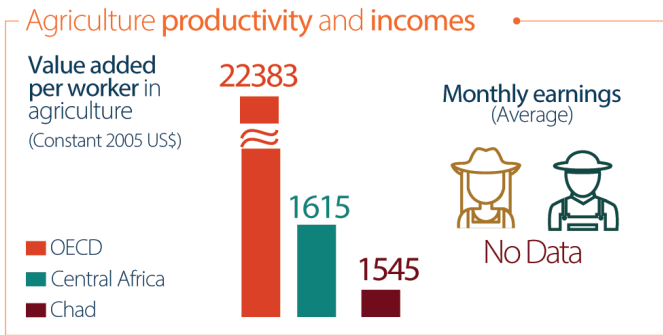

## Land use

Chad covers 1,284,000 km<sup>2</sup> of land area and has enormous agricultural production potential, including 50,238,000 hectares (ha) of agricultural land, or 39% of the country [11] (Figure 3). Cultivable area and permanent grassland account for 4% and 38% of the total land area, respectively; 4% of Chad is under forest cover [12]. Agricultural production systems in Chad are extensive and have low yields. Family-based, subsistence-oriented agriculture predominates; most agricultural activities are practiced on small plots of 2-5 ha for rain-fed crops and of 0.1-1 ha for irrigated crops. To expand current production systems by improving water management, public and private hydro-agricultural infrastructures have recently been implemented. Nevertheless, irrigation sub-sector has room for continued development and increased performance. While the potential irrigation surface is estimated at 335,000 ha, the area that is both equipped and irrigated was only 26,200 ha in 2017 [13].

Formal and informal systems of land governance co-exist in Chad. Land system dynamics are complex and include the postcolonial land system, new legislative requirements, and traditional practices such as community ownership of land and land use rights, the Islamic land tenure regime, the role of chiefdoms, and inheritance customs. In practice, access to arable land is governed by common law, especially in rural areas. Expanding into unconstrained, cultivable areas allows farmers to increase agricultural production; they must have easy access to land and the ability to operate in complete safety on it. Current land rights practices in some places discriminate against most women and against particular social castes. Chad's caste system stratifies individuals according to their ancestry and occupation. In the large hydro-agricultural developments implemented by the Government of Chad, parcels are awarded according to the regulations established on plots by their management committees [14].

The land use in Chad is changing; as of 1990, vegetation covered 23.1 million ha, or about a quarter of the country. This area had decreased to 21.7 million ha by 2005, in part due to practices such as the exploitation of wood resources for energy needs, clearing land for agriculture, and

urbanization in the context of rampant population growth at a rate of 3.6% annually [15]. Agroforestry is also booming across Chad's agroecological zones. Shea, cashew, castor, and moringa trees are now part of plantations in the Sudanese Zone. Gum Arabic provides income for more than 300,000 households in the Sahelian Zone; for some rural populations, this crucial resource represents 15-30% of their income.

Chad has enormous livestock production potential. The country's livestock head count was 93.8 million cattle and 34.6 million poultry units as recorded by the Ministry of Livestock in 2018 [16]. Chadian livestock farming is mainly extensive. It engages, directly or indirectly, 40% of the population. Despite its importance and the huge potential of the Chadian herd, meat production is not sufficient to meet demand [17]. Poultry farming has remained traditional and is being modernized slowly.

Natural pastures are the main food source for livestock [18]. Along with rangelands, they cover more than 84 million ha, or 65% of the total surface area of the country. A precise assessment of exploitable surfaces for livestock is difficult, but by referring to climatic zone patterns, 4 types of pastures may be identified:

- **Saharan** pastures have a relatively low average annual productivity; the production of dry matter is about 400kg/ha/year. Fodder crops are cultivated in oases.
- **Sahelian** pastures comprise the country's largest farming zone, and are characterized by shrubby-to-thorny savannas. Their average dry matter production is on the order of 300 to 1500 kg/ha/year.
- **Sudanese** pastures occupy an ecosystem that gradually extends from shrubby savannas to wooded savannas. These pastures feature perennial grasslands whose dry matter productivity ranges from 1300-3000 kg/ha/year.
- The declining, or **Yaéré**, pastures are large areas of non-shrubby grassy savannas that are regularly covered by floods. These grass-based pastures, which give way to high-quality regrowth after stubble burning, support dry-season production of dry matter of 2600 and 4000kg/ha/year.

Both surface and groundwater are available for livestock exploitation. Around a third of the water (30%) provided to animals originates from perennial surface water supplies, 15% comes from temporary surface water, 35% from sumps and traditional wells, and 20% from modern wells [18].

**Figure 3. Land use in Chad**

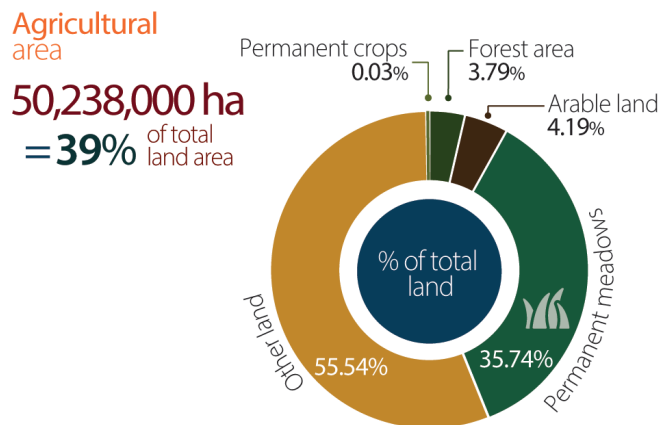

## Agricultural production systems

Chad features a hot, continental climate. Rainfall ranges from 50-1,200 mm per year; amounts vary geographically, which influences the agricultural production systems practiced from one agroecological zone to another. Rainfall in Chad is characterized by high annual variability and significant drought risks in some agroecological zones:

- The **Saharan Zone** in the north of the country, accounting for 47% of the total land area and inhabited by 3% of the total population, receives little rainfall, just 50-200 mm per year. Agricultural production here involves pastoral and transhumant activities, particularly breeding dromedary camels. Agricultural production happens in the beds of desiccated rivers (wadis) and is focused on vegetables, dates, and certain varieties of millet.

- In the center of the country, the **Sahelian Zone**, comprising 28% of the land and home to 47% of

the population in 2011, has an annual rainfall range of 400-800 mm per year. It is suitable for livestock breeding and the cultivation of food crops, including wheat, corn, rice, berber, sorghum, peanuts, onions, garlic, and fruits. Agroforestry systems have been developed in both the Sahelian and Sudanese regions.

- To the south, the **Sudanian Zone** experiences relatively plentiful rainfall measuring 800-1,200 mm per year, and enjoys abundant water resources. Containing 50% of the population as of 2011 [6, 18], this area offers opportunities for crop diversification, including rice, maize, sorghum, millet, legumes, vegetable and fruit crops, roots, and tubers [6, 19]. The Sudanese area is the breadbasket of the country.

Agricultural systems in Chad are rain-fed, flood-recession, or irrigated. Typically, rain-fed crops include cereals, such as maize, millet, and sorghum; oilseeds like peanuts and sesame; protein crops like beans and ground peas; and tubers, such as cassava, potatoes, and taro. Rain-fed agriculture is the main system utilized by family farms and, thus, generates the bulk of Chad's agricultural production. Market-garden belts are developing in proximity to towns [20]. Market gardening engages 21% of the urban labor force [21]. Flood recession and off-season cultivation are oriented towards market gardening, which has become a profitable activity for women, young people, and producers' organizations.

Several agricultural production systems are crucial to Chad's food security. Their importance is based on their contributions to quality indicators related to economic factors, productivity, and nutrition. Analysis for this report was based on data from 2012-2016, the most recent available [22, 24] (Figure 4).

Nutritional indicators were drawn from the International Network of Food Data Systems (INFOODS), the food

**Figure 4. Production systems key for food security in Chad**

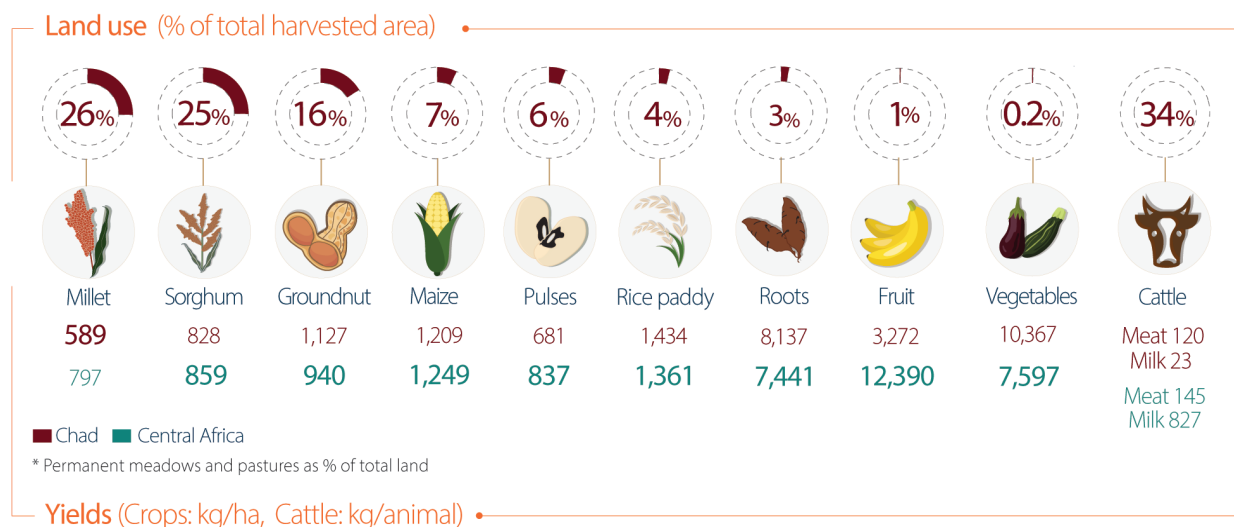

composition database of the Food and Agriculture Organization of the United Nations (FAO) [22], which provides an overview of long-term trends and patterns in per capita food availability, food groups, major food products, and macronutrients at the national level. In Chad, sorghum and millet provide the most energy, averaging 308 and 408 kcal/capita/day, respectively (Figure 5). These are followed by oilseeds, averaging 197 kcal/capita/day; maize, providing 130 kcal/capita/day; and roots and tubers, which furnish 148 kcal/capita/day on average [23]. Economically, oilseeds and cattle farming contribute 4.5% and 2.29% of Chad's GDP, respectively [3, 23].

**Figure 5. Economic relevance and nutrition quality of key crops in Chad**

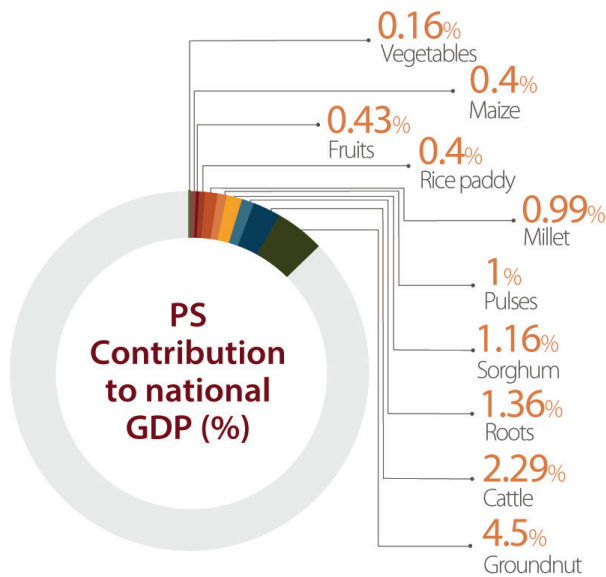

Although it is still traditional in nature, the agricultural sector in Chad is undergoing a transformation. Extensive, subsistence farming is currently the main production system in Chad, and most production happens on family farms. However, new stakeholders are emerging through increasingly significant investments. Changes are taking place in terms of irrigation schemes and input use.

Chad has extensive underground and surface water resources—20.6 billion m<sup>3</sup> renewable and 263-554 billion m<sup>3</sup> exploitable—that remain underutilized [25]. Water courses such as Lake Chad and the valleys of the Logone and Chari rivers offer possibilities for significant agricultural operations. Of the 335,000 ha of potentially irrigable land (Figure 6), 30,000 ha are in operation, of which 26,200 ha are currently irrigated, including 2,000-3,000 ha in private rice or market garden production. The performance of the current hydro-agricultural developments in Chad are variable 78% are poor performers or shut done. Only 22% have acceptable performance. At this point, there are no hydro-agricultural developments classified as efficient or very efficient in Chad [26]. Funding remains a major challenge to the improvement of these infrastructures.

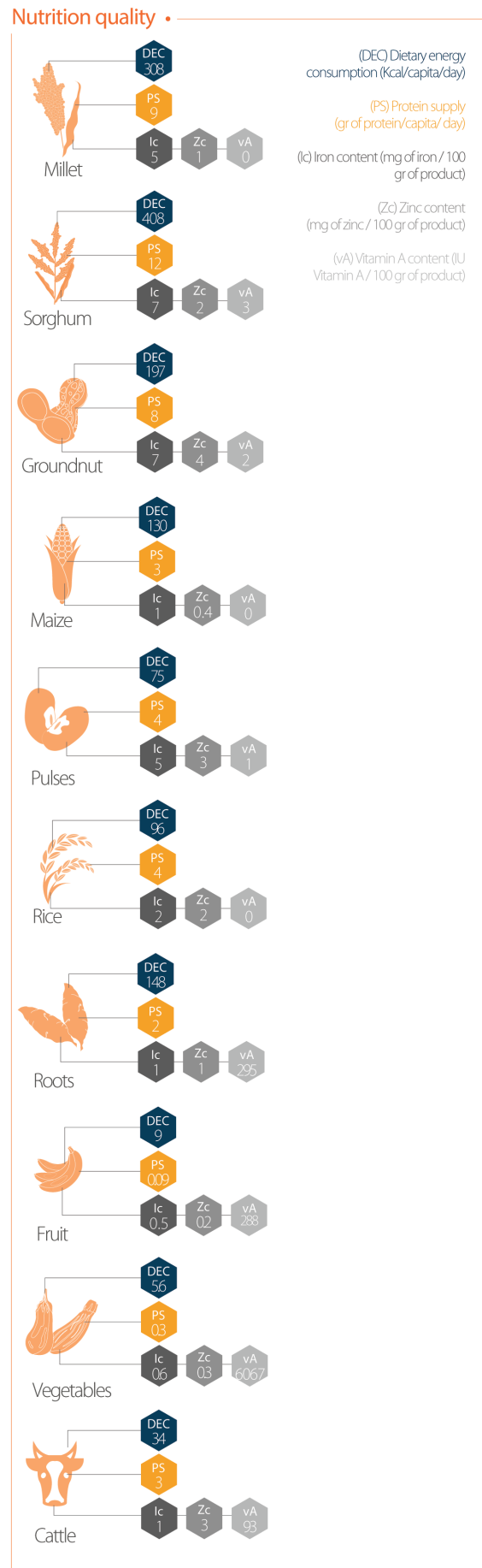

Access to agricultural inputs is low, particularly for improved seeds (5%); phytosanitary products for the control of pests and diseases (15%); and targeted fertilizers, especially in the cotton, market gardening, and rice cultivation subsectors [21, 25]. Disparities in access are driven by the proximity and availability of services. National agricultural statistics and surveys do not yet provide an updated picture of input access. Annual demand was estimated to be around 60,000 tons (excluding the cotton value chain). Chad adopted a new national strategy for agricultural mechanization in 2019 that encourages and facilitates the use of tractors and other agricultural equipment. The government of Chad has made 3,000 tractors available for producers across the country [27].

**Figure 6. Agriculture input use in Chad**

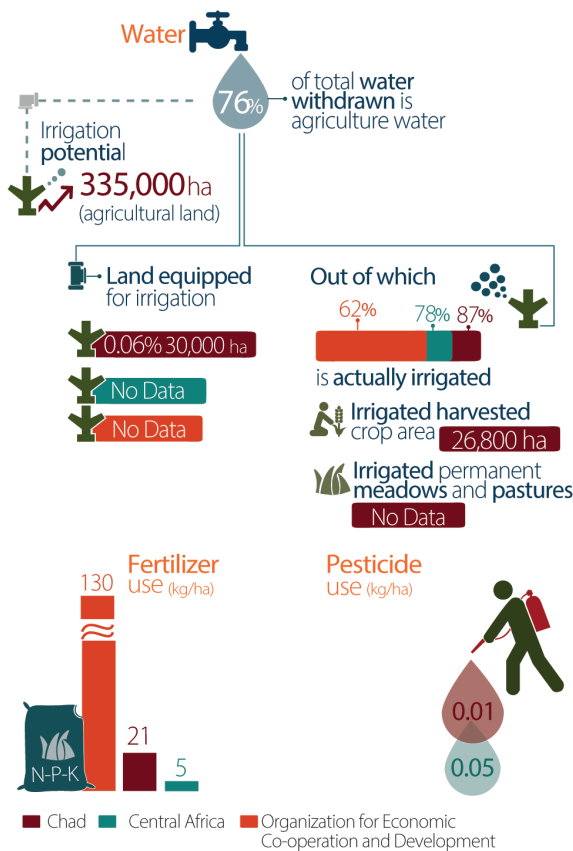

## Food security and nutrition

The food and nutritional situation in Chad is worrisome. The country has multiple indicators of chronic undernourishment affecting 4 out of 10 people; as a result, the country's Global Food Security Index score is 39.4 [28] (Figure 7). The Global Hunger Index ranks Chad 107th out of the 107 countries with sufficient data for ranking, indicating an alarming level of hunger [29]. Food security research led by the World Food Program demonstrates that 17 of the 20 departments with a

high level of food insecurity are located in the Sahelian Zone, based on 2011-2016 data [30]. More recently, the results of the 2019 Standardized Monitoring and Assessment of Relief and Transitions (SMART) survey reveal almost a 13% prevalence of Global Acute Malnutrition at the national level. This represents a high level of malnutrition according to the standards set by the World Health Organization. Stunting rates of over 30% are documented in 12 of the country's 23 provinces [31]. Some populations—particularly female-headed households, refugee populations, and internally displaced persons—are disproportionately affected by food insecurity.

**Figure 7. Food security, nutrition, and health in Chad**

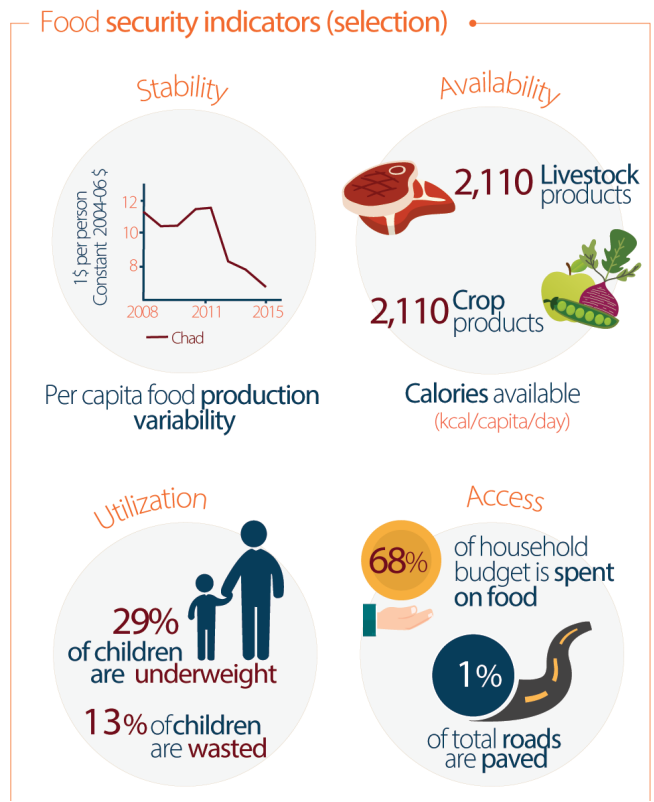
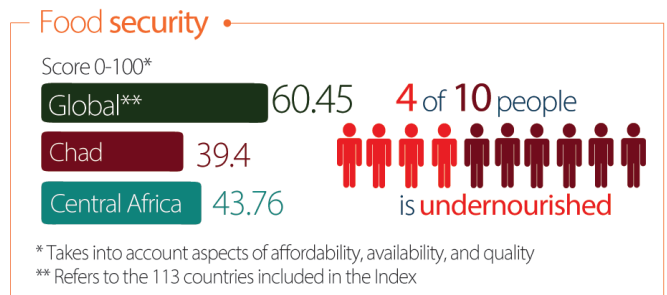

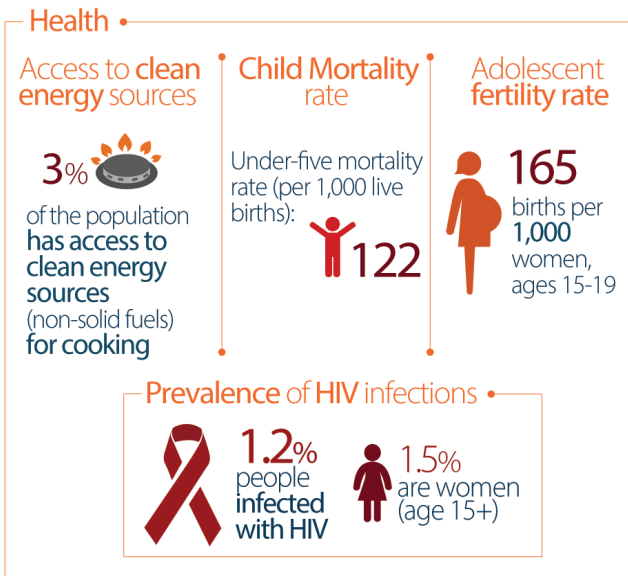

Several factors contribute to recurring food insecurity and malnutrition. The subsistence production systems that dominate the agro-sylvo-pastoral sector do not ensure the availability of consumer products. Cereal availability varies with rainfall and post-harvest phytosanitary conditions. The annual cereal production faced deficits for nine non-consecutive years between 2000 and 2018; more recent years have seen an increase in production [32].

Climate change, rainfall variability, a lack of infrastructure, and poor management of water and land resources impede the development of agricultural production systems in Chad. Demographic growth, persistent poverty, herder-farmer conflicts, national insecurity, vulnerability to shocks, nutritional insecurity, and gender inequality exacerbate these challenges.

## Greenhouse Gas Emissions from the Agricultural Sector

Ranked 207th out of 210 countries worldwide in terms of GHG emissions, Chad sequesters more GHGs than it emits. In 2016, the carbon dioxide emission rate was relatively low at 0.07 MtCO<sub>2</sub>eq per person, compared to the average rate in Sub-Saharan Africa of 0.83 MtCO<sub>2</sub>eq per person, which itself was quite low on the global stage [33]. Chad's total GHG emissions are around 91 MtCO<sub>2</sub>eq, less than the estimated average of the Central Africa region of 102 MtCO<sub>2</sub>eq (Figure 8). The agricultural sector generates 66% of country's emissions. The government of Chad has taken measures to reduce GHG emissions by 71% by 2030 (conditional contribution) to limit the effects and impacts of climate change [34]. These measures include bans on fuelwood and charcoal manufacturing, and the introduction of a subsidy for gas consumption [34].

In the context of agriculture with low mechanization rates, livestock production generates the bulk of GHG emissions (about 80%). Enteric fermentation is primarily responsible, representing more than 47% of the livestock subsector's

emissions. Manure on pasturelands contributes upwards of 30%, followed by manure management (2%) and the application of manure to soils (0.5%). Crop production contributes more than 19% of Chad's total emissions, the main sources of which include burning of savannas (10%), the use of synthetic fertilizers (9%), rice production (0.4%), and of crop residues (0.4%) or their burning (<0.1%). The country plans to continue reducing emissions while simultaneously developing its economy. Chad's nationally determined contributions anticipate the development of agro-sylvo-pastoral and fishery practices, as well as the implementation of environmental protections and a sustainable natural resource management program to serve mitigation goals [34].

Figure 8. Greenhouse gas emissions in Chad

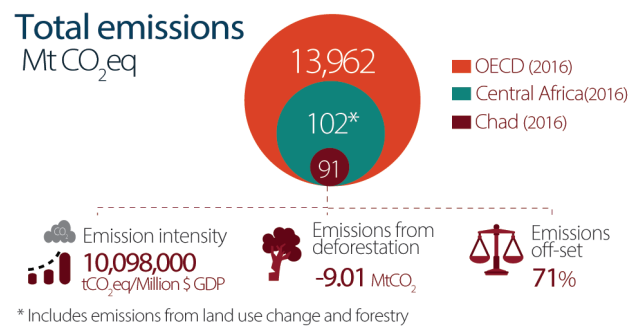

## Sectoral emissions (2016)

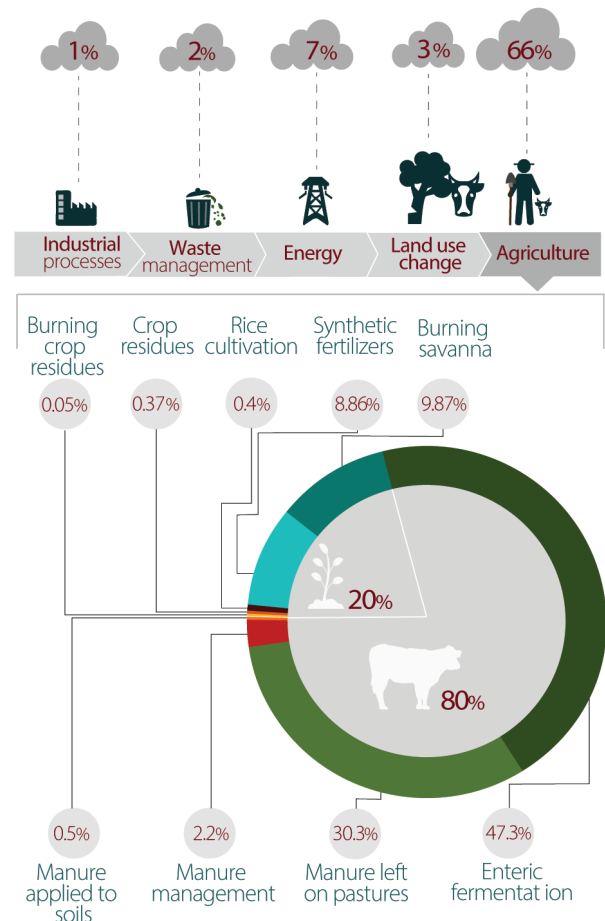

## Challenges for the agricultural sector

Chad's agricultural sector faces major, multifaceted challenges. Agricultural production systems are still extensive and largely subsistence-level in nature. Their low yields are insufficient to meet the needs of the country's rapidly growing population. Food production remains a major challenge in the country with the majority of the food insecure population living in the Sahelian zone which contains 47% of the population.

Climatic variations and extreme events also present important complications: agriculture is currently primarily rain-fed, and thus is extremely affected by rainfall variability. Droughts and floods also have an immediate and outsized impact on food security, given that 77% of the population work in agriculture.

Water management is critical and is facing major constraints in Chad. There is a clear lack of efficient hydro-agricultural facilities with many infrastructures needing renovations or simply not working anymore. Irrigation efforts are also constrained by lack of access to facility and basic infrastructure. An overall lack of national and international funding impedes the improvement of water management structures. Agricultural sector stakeholders lack access to inputs such as seeds, fertilizers, pesticides, and equipment; water control; extension services (in 2012, the country was employing 717 staffs dedicated to extension [35]); information services; and modern technologies. Poor infrastructure (more than 6000 km of national roads of which 2082 km were paved road in late 2014 [36]) and limited production impede agricultural engagement in local and international markets, thus drastically reducing potential revenues and buying power and increasing transaction costs. Finally, the agricultural sector is both a forum for and a victim of security problems. Pressures exerted on water and land resources exacerbate long-held conflicts between local herders and farmers.

Private sector engagement is weak. Improved financing mechanisms are sorely needed by stakeholders across the agro-sylvo-pastoral production chains. These challenges are compounded by structural constraints that reduce the scope of investment efforts by the government and its partners in the sector. Moreover, unfavorable business climate discourages private investment by subjecting small- and medium-scale enterprises to costly and time-consuming regulatory procedures, starves them of the financing needed to grow and diversify, and frequently subjects them to extortionary practices by rent-seeking public officials.

The public institutions working on agriculture in Chad are fragmented, understaffed, and inconsistently managed. Responsibility for key functions is distributed across multiple ministries and agencies, so it has been difficult to forge an overall vision for the development of the sector. In addition, inconsistent policies have negative effects such as the subsidies provided by the Government of Chad given to the fertilizers which distort the market and make it difficult for the private sector to compete.

Finally, lack of land tenure security due to continuing

reliance on traditional systems of land allocation and administration discourages investment in productivity-enhancing improvements (as demonstrated by the recently completed Chad Land tenure and productivity ASA).

## Agriculture and climate change

### Projected Changes in Temperature and Rainfall through 2080

Chad's climatic profile is characterized by variable rainfall rates across three agro-climatic zones: Saharan, Sahelian, and Sudanese. Rainfall is extremely low, measuring less than 100 mm per year in the northern half of the country, but annual amounts increase along a north-south gradient; they can reach over 1,050 mm per year in the far south. The rainy seasons follow this gradient as well, beginning the in the south and gradually moving north. Temperatures can reach up to 45°C during periods of extreme heat from March to June, and are cooler from November to February [37].

The last two decades have witnessed major climatic changes in Chad. This alteration is particularly evident in rainfall variability marked by the sudden alternation of wet and dry years from the 1990s to the present day; minimum and maximum temperatures that have risen over the last two decades by +1.5° C and +1° C, respectively; and an increasing incidence of major climatic events like droughts and floods. The droughts of 1972-73 and 1984 were particularly destructive. Major floods were recorded in 1988, 1999, 2005, 2006, 2007, 2008, 2010, 2012 and 2020 [38]. Future climate projections suggest that temperatures will continue to climb, with an increase of 2°C by 2030 and 4.5°C by 2070 (Figure 9). Global warming effects will manifest more significantly in the northern part of the country, where temperatures were historically the lowest. Projections show that this region will experience an increase in temperature of up to 3°C by 2050 and 5°C by 2070 [39].

Likewise, rainfall amounts will increase in Chad; a pronounced increase of up to 300 mm is projected for the east by 2070 (Figure 10). The south, which is currently the most humid region in the country, will see a smaller increase of up to 150 mm by 2050. Some very arid areas will not see any additional rainfall by 2050. Notably, rainfall projections are unclear; different models have shown inconsistent projections for the entire West African region. Most likely, rainfall will begin increasingly to fluctuate, becoming more unpredictable in the years ahead. Major climatic events, such as droughts and floods, will also likely grow in frequency and intensity.

Given that most subsistence crops and some cash crops, such as cereals and oilseeds, are rain-fed, significant changes in precipitation will heavily and directly affect Chadians, particularly the 77% of the population who work in the agricultural sector. In the medium term, climate change degrades land, water, and pasture resources, further compromising potential future productivity.



**Figure 9. Projected temperature changes in Chad through 2080**

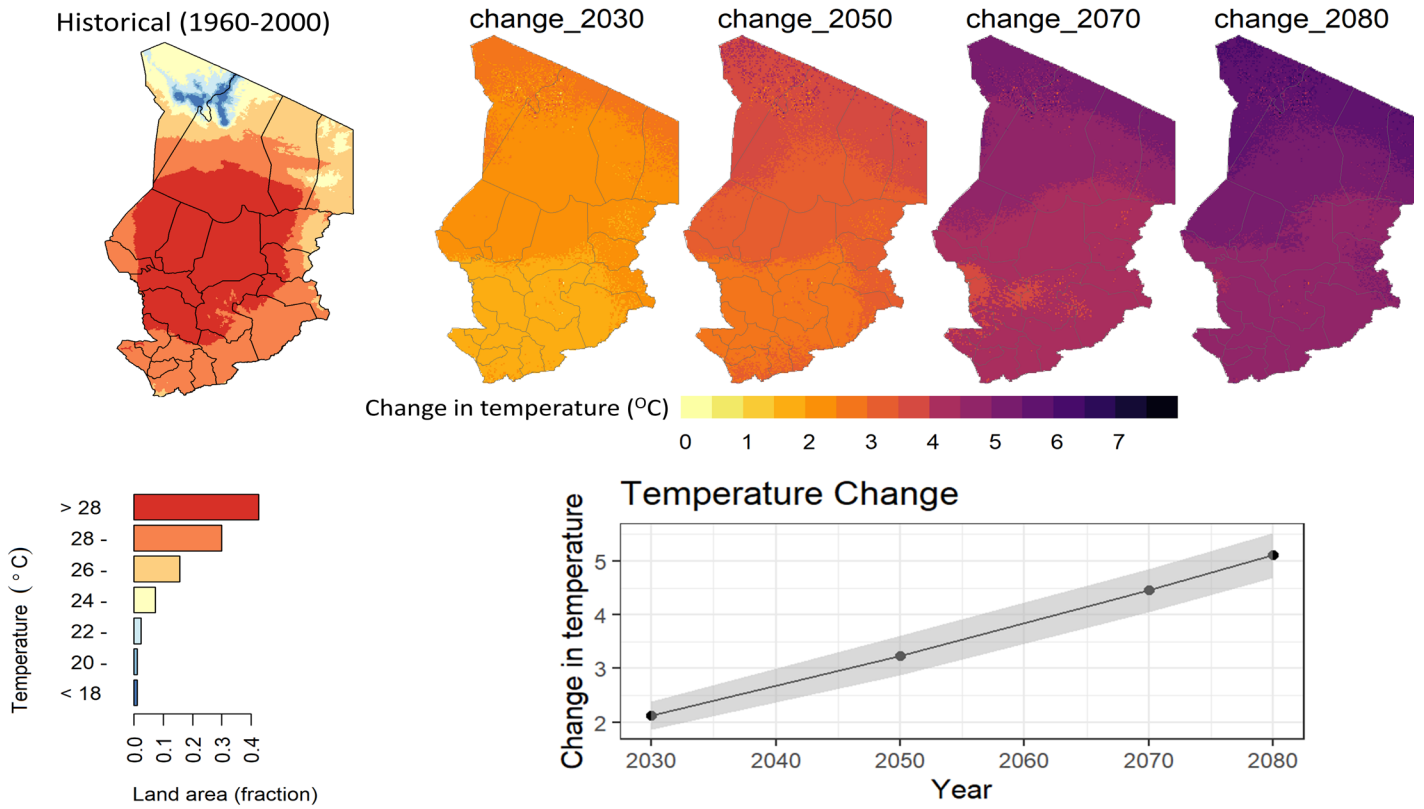

**Figure 10. Projected rainfall change in Chad through 2080**

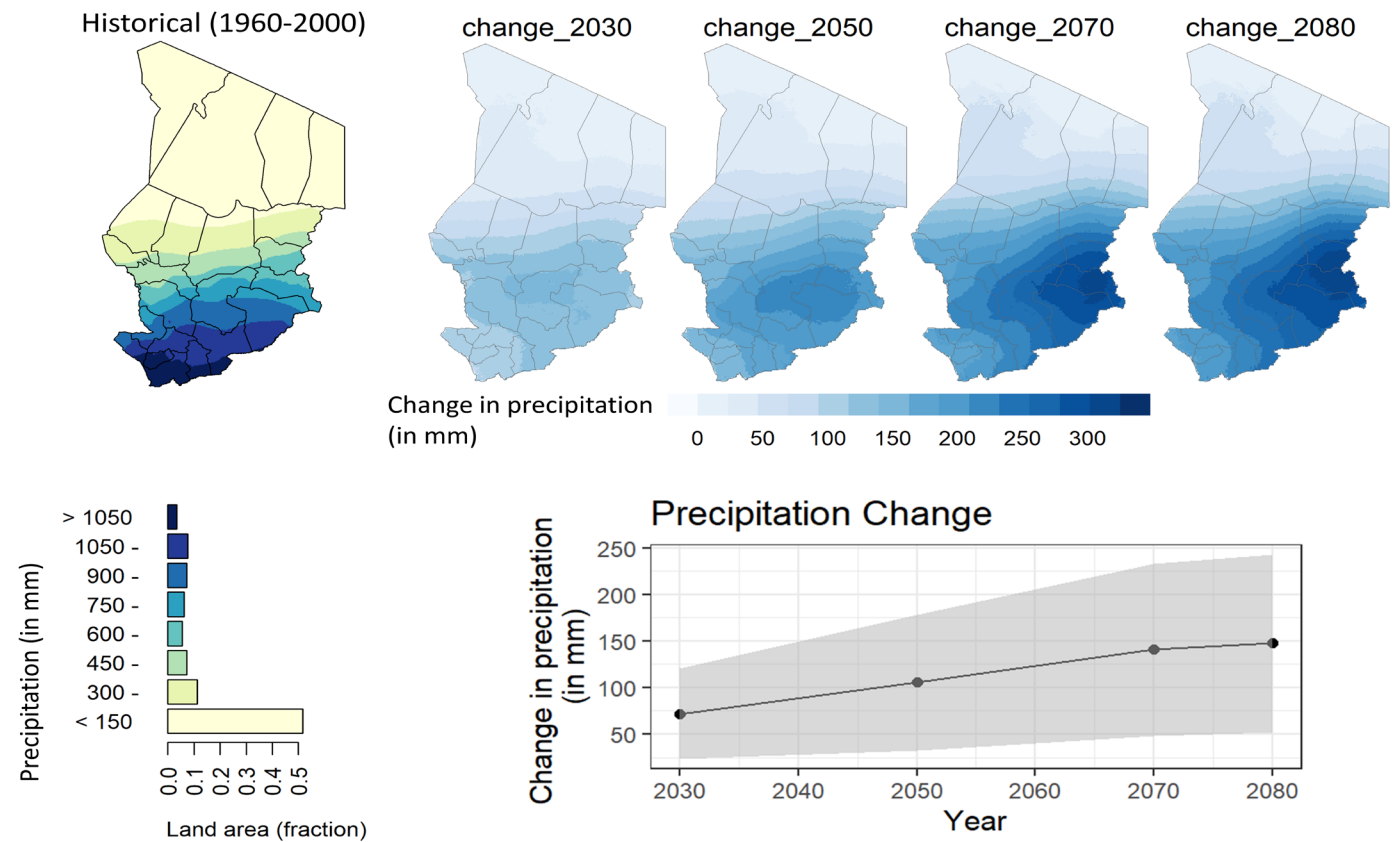

## Economic Impacts of Climate Change

The International Model for Policy Analysis of Agricultural Commodities and Trade (IMPACT) is an exploratory tool that uses provided scenarios to assess the links between agricultural policy, climate change, and technologies in agricultural systems. The model results are aggregated at the national level for a range of parameters, including prices, food security, area under cultivation, yield, and demand. Collectively, the results consider climatic, socioeconomic, and crop scenarios. Using IMPACT modeling, we can illustrate potential regional differences in climate change impacts, as well as in associated technologies and policies.

Several outcomes are possible when examining the consequences of climate change against a scenario without climate change. The modeled variables show the impacts of three scenarios—the Representative Concentration Pathways RCP 4.5, RCP 8.5, and no climate change<sup>1</sup>—to allow for comparison. The increases and decreases in the response of each variable are relative; for example, a crop's yield may still increase under climate change conditions, but less than when compared to a scenario without climate change, indicating that the effects of climate change are still adverse.

## Variations in Yield, Area Sown, and Number of Animals

Yields of major crops in Chad are projected to be lower under climate change than under a no-climate change trajectory through 2050. This does not necessarily mean that yields are projected to decrease below their current levels. Rather, this means that future yields are projected to be lower than they would have been in the absence of climate change (Figure 12). The most severely affected crops are maize, vegetables, groundnuts, and millet. Yield reductions are generally more severe for RCP 8.5.

Area harvested is likewise projected to be lower under climate change than under the no climate change benchmark for maize, beans, and vegetables. Again, this does not imply that area harvested will decrease below current levels. In fact, vegetable area is projected to increase through 2050, but this increase is projected to be less than it would have been in the absence of climate change (Figure 11). Maize area harvested is projected to increase through 2040, and then to decline back to current levels by 2050. Area reductions are generally more severe under RCP 8.5 than under RCP 4.5. Millet, rice, cassava, fruit, and groundnut area harvested is projected to be higher under climate change than under the no-climate change benchmark, while livestock numbers are projected to be only slightly lower than their no-climate change trajectories.

**Figure 11: Area sown for maize and vegetable for the 3 scenarios (RCP 4.5, RCP 8.5 and no climate change)**

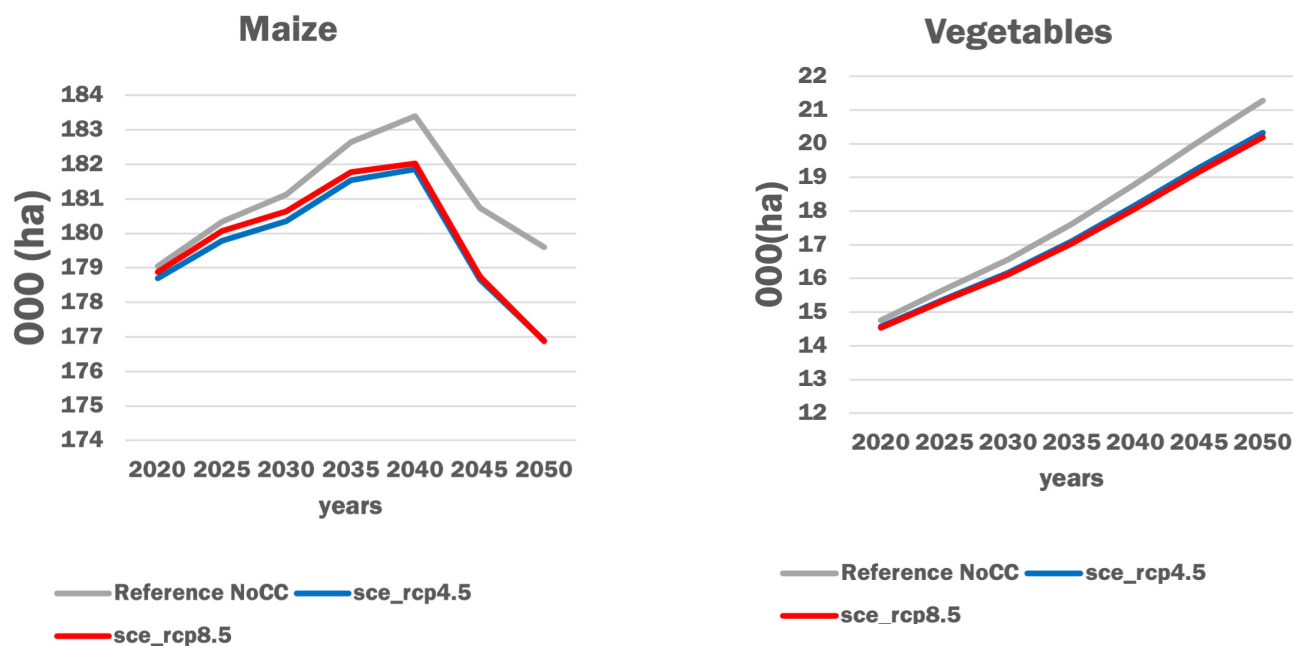

<sup>1</sup> The Representative Concentration Pathways (RCPs) RCP 4.5 and RCP 8.5 describe two potential climate futures, considered possible depending on the amounts of greenhouse gases emitted in the coming years. RCP 4.5 represents an intermediate scenario and assumes that global annual GHG emissions will peak by 2040 and decline thereafter. RCP 8.5 considers a very high emissions scenario involving rising emissions throughout the 21st century.

**Figure 12: Projected climate change impacts through 2050 on yield, area cultivated, and animal numbers under scenario RCP 8.5 for selected agricultural commodities in Chad. ‘% difference’ refers to the difference between the climate change scenario (RCP 8.5) and the no-climate change scenario.**

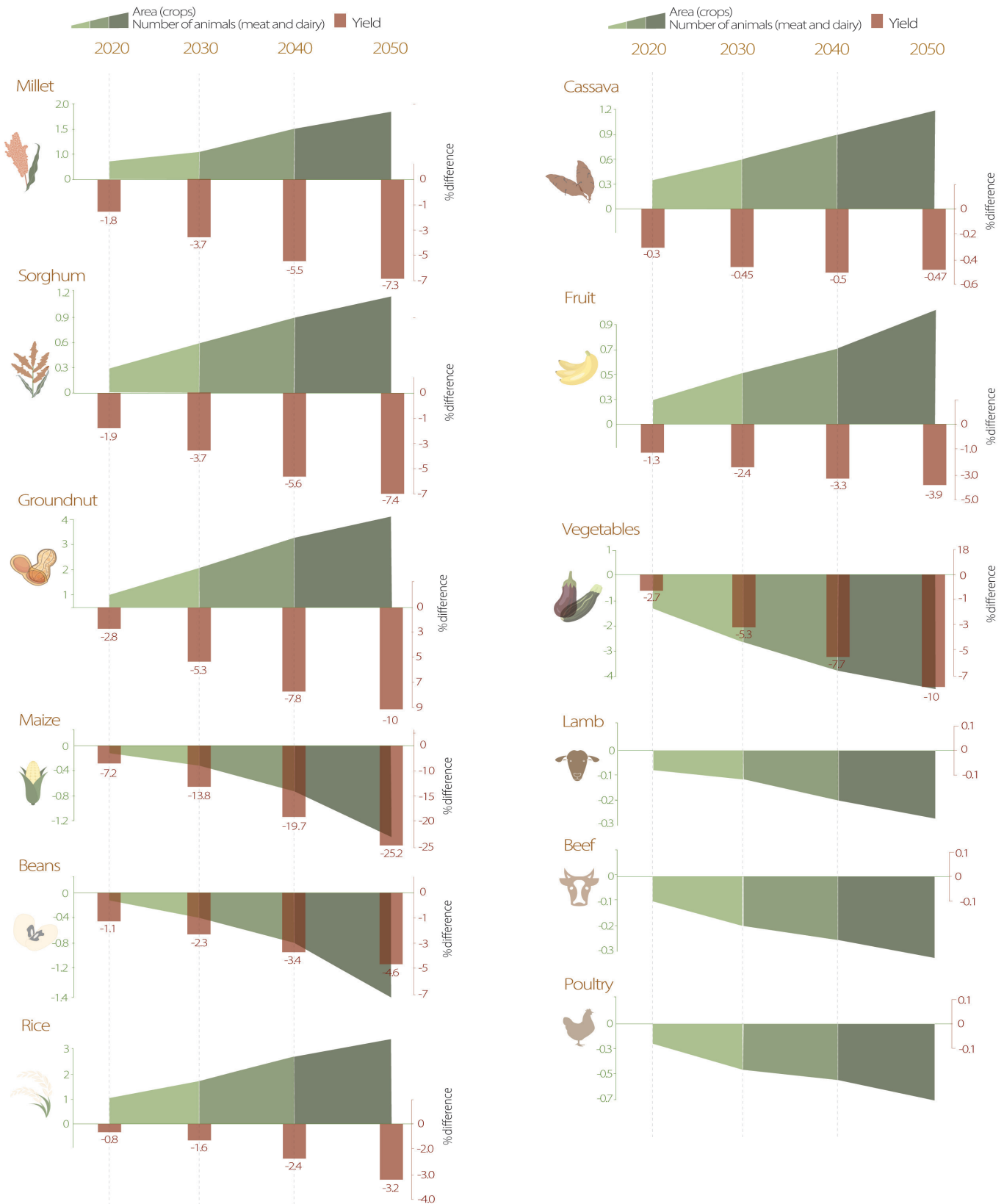

## Changes in Net Trade

Climate change impacts on international trade are represented as gaps between local production and local demand for each production system. This is calculated as the difference between the country's net trade growth with and without climate change.

The balance of trade for sorghum, beef, rice, and maize is projected to remain negative and become even more marked through 2050; sorghum and maize in particular will see an import increase (Figure 13). During the year 2050, the projected negative trade balance for sorghum and maize is more pronounced under the climate change scenarios

(RCP 4.5 and RCP 8.5) than under the no-climate change benchmark scenario. This may be linked to the decline in yield of these commodities (Figure 14).

Beans and cassava currently have a negative trade balance. The balance is projected to remain negative going forward, but the extent of this negativity will lessen with falling import. Groundnut and millet have a projected positive trade balance through 2050 that is less pronounced under climate change than under the no-climate change benchmark, meaning that the positive net trade in these commodities is projected to be less under climate change than what it would have been in the absence of climate change.

**Figure 13: Projected impacts of climate change (scenario RCP 8.5) on net trade in Chad through 2050**

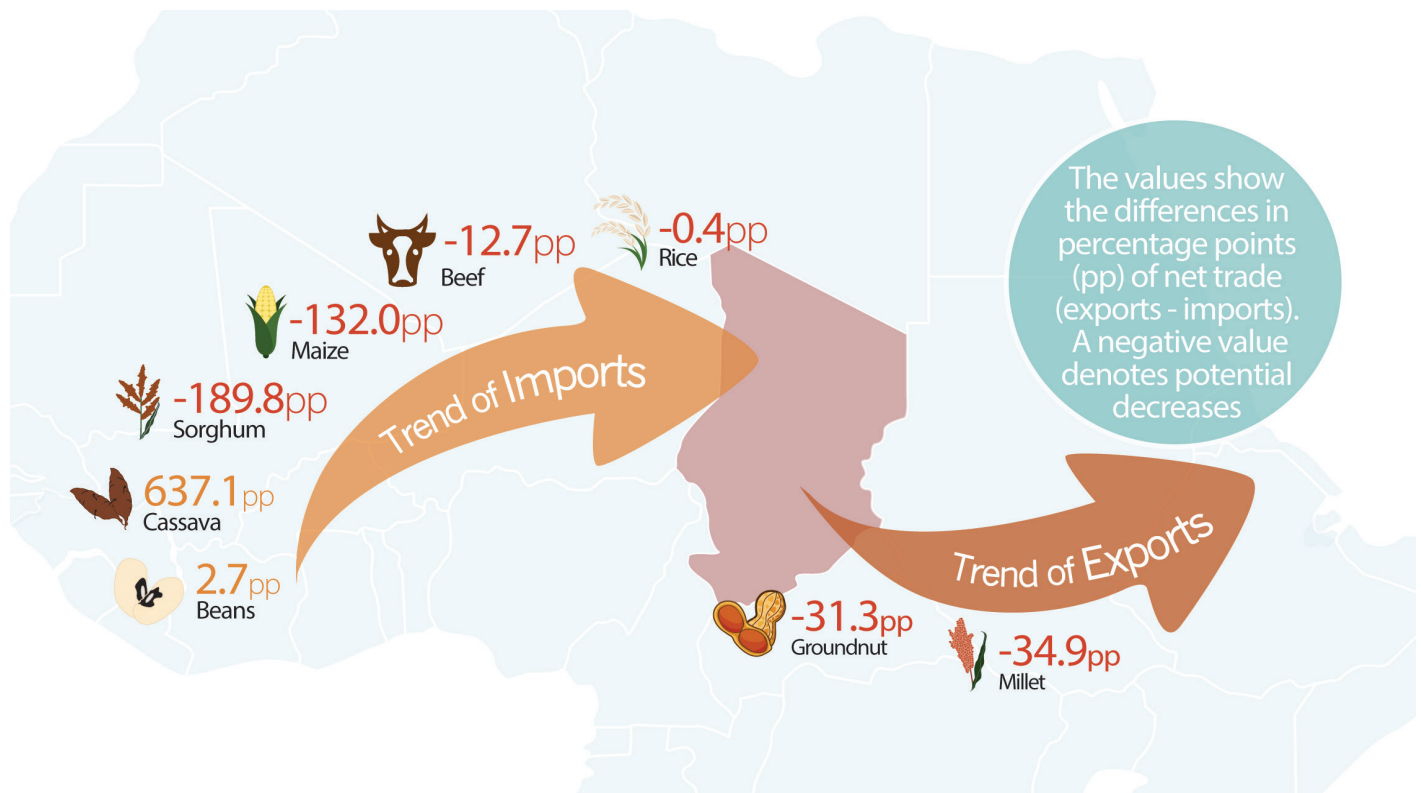

Figure 14: Net trade of main crops and livestock in Chad in metric tons for scenario RCP 4.5, RCP 8.5 and no climate change scenario (NoCC) for the year 2050

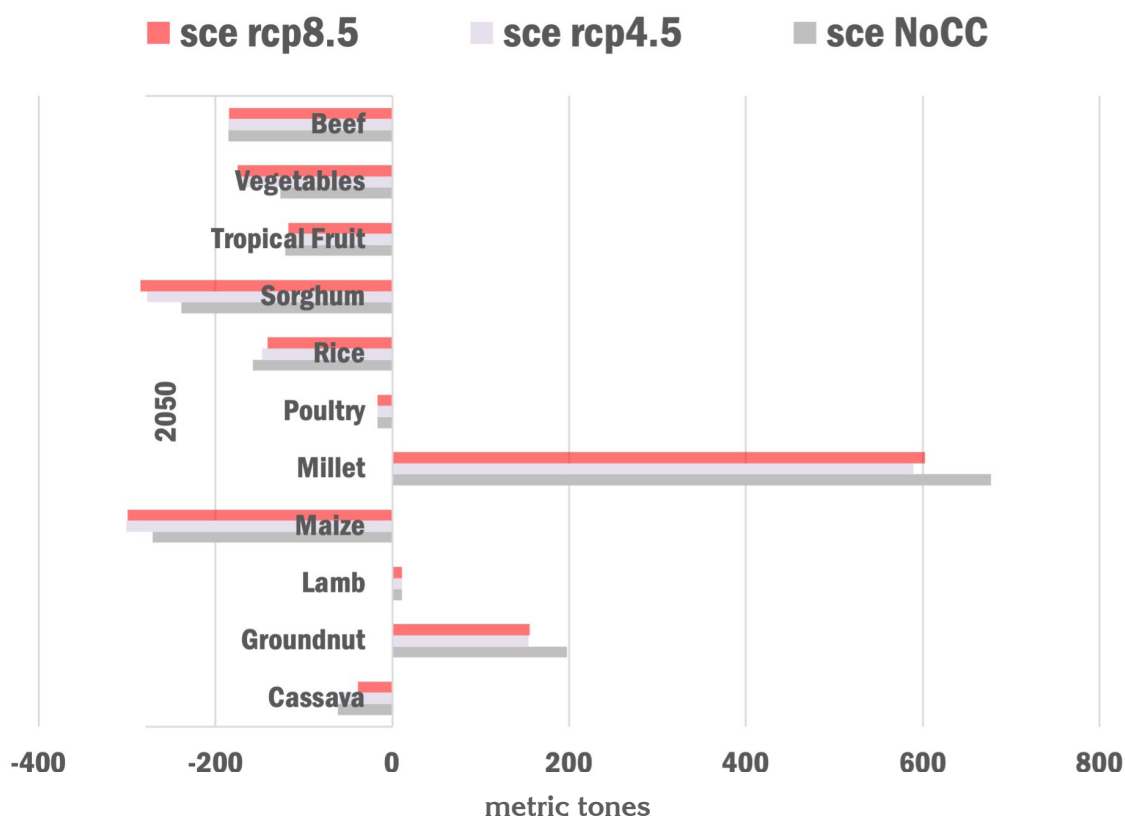
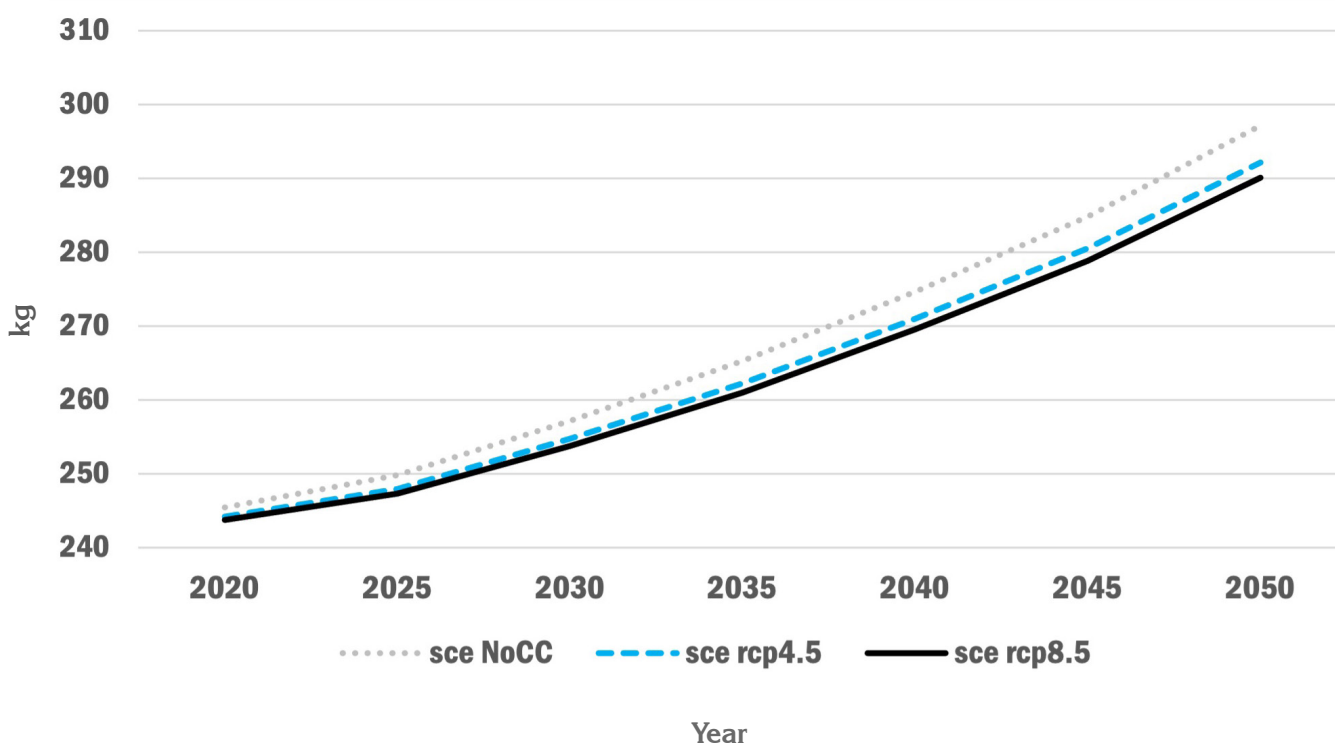

Figure 15: Quantity of food available per person per year until 2050



## Perspectives for Food Security

Among the results of the IMPACT modelling, the following considerations are of particular importance for the future of climate change and food and nutritional security in Chad.

Crop yields for key staples such as maize, vegetables, and sorghum are projected to be lower under climate change than under the no-climate change benchmark scenario. As demand exceeds supply by 2050, many crops will need to be imported. Sustainable interventions to increase farmers' yields could help prevent a growing import dependency.

Groundnut and millet show a tendency toward export by 2050. Interventions that increase post-harvest or post-production processing could help further augment export opportunities for farmers. Diversification of the varieties and value-added products of all commodities for export—including livestock products—could further boost income security under climate change.

The number of products tending toward increased import by 2050, and particularly staple crops like maize and sorghum, suggests that Chad's food self-sufficiency is under threat. Climate change is projected to exacerbate this trend in the case of maize, vegetables, and sorghum.

Food availability per capita is projected to decrease under climate change (as compared to a no-climate change scenario) by up to 7 kg per year, with outsized impacts on sorghum and millet availability (Figure 15).

## CSA technologies and practices

CSA technologies and practices offer an opportunity to address the challenges of climate change while fostering the economic growth and development of the agricultural sector. For this profile, practices are considered climate-smart if they strengthen food security in addition to meeting at least one of the other CSA objectives; adaptation and mitigation. Hundreds of technologies and approaches currently in use all over the world fall under CSA.

Several practices aligned with CSA objectives are already supporting adaptation to climate variability in Chad. Some are derived from traditional practices; others have been implemented through specific projects and programs. CSA practices can be grouped according to their objectives, e.g., water management, soil management, crop management, and livestock and fodder management [40, 41, 42, 43, 44, 45, 46, 47, 48, 49]. Productivity and adaptation are the main priorities for developing climate change solutions in Chad.

Water management practices aim at improving water infiltration, maintaining soil structure, and retaining soil nutrients. They improve production in the face of drought and dry spells [44]. Water and land management efforts

happen at both the landscape and field levels. At the field level, water management takes the form of constructing stone bunds, semi-circles, water-spreading weirs [45], and implementing irrigation technologies like criptopumps, which operate via solar energy and mechanical pedaling. Land management practices, such as using zai or half-moon pits, help restore degraded soils and rehabilitate abandoned lands by supporting the infiltration of water into the soil in combination with manure or compost fertilization. The construction of hydraulic and hydro-agricultural developments concentrates climate adaptation efforts at all levels. Public, private, and community investment in hydro-agricultural installations (e.g. dams, irrigated areas, weirs) and pastoral wells have been the main response.

Intercropping and the use of manure and compost are the soil management practices most commonly used by Chadian farmers to increase soil fertility and thus crop yields [42]. Intercropping contributes to the enrichment of soils. The most common intercropping associations are millet or sorghum with groundnuts; millet or sorghum with cowpeas; and cassava with sorghum. The crops that are associated with cereals provide beneficial effects by releasing nitrogen into the soil. Fertilizers, including manure, compost, and agricultural by-products, are generally applied to the most important crops, with agroforestry systems mainly using organic fertilizers. Like most agricultural inputs in Chad, fertilizers are accessible because of a supply policy based on state subsidies; this program is experiencing difficulties linked to the current economic crisis. The lack of extension agents specializing in fertilizer use is an additional challenge. Some producers in Chad are experimentally fertilizing soils with acacia albida.

Crop management practices are also found in Chad. Drought, rainfall variability, and reduced length of the growing season all decrease crop production [43]. Producers are increasingly using improved and adapted crop varieties, which are quickly replacing traditional varieties. This is the case for cereal crops like rice, maize, sorghum, and millet. It is likewise the case for cassava: long-cycle varieties that have a maturation period of six months have been supplanted by those with shorter cycles. Improved varieties of groundnuts and cowpeas are popular in both the Sahelian and Sudanian Zones. In general, however, access to adapted or improved varieties remains limited due to seed availability.

Lack of pastures, changes in the transhumance routes, local conflicts between farmers and pastoralists, declining production, and epidemics are potential consequences of drought, floods, and pest diseases on livestock [42]. Livestock and fodder practices are key to improving production while contributing to mitigation efforts. Pastoral production of cattle, sheep, goats, and camels is adapting to climate change through the development of fodder banks for transhumance, which helps to protect animal health and to prevent farmer-herder conflicts. Feed supplements and improved varieties of fodder grasses and legumes are also being developed by both professionals and individual

producers [46]. Improved fodder varieties increase production by providing better quality, they improve soils by fixing nitrogen, and they contribute to mitigation efforts.







In addition to these selected practices, it is worth mentioning other initiatives that contribute to CSA pillars in Chad but which are not yet widespread. The digitization of innovative technologies and practices is an element of various initiatives currently in the experimentation phase. Emerging multi-stakeholder platforms bring together producers, the private sector, consumers, and other key stakeholders. They provide information on emerging agricultural value chains and platforms for experience sharing, service provision, and the capitalization of existing solutions. In the field of GHG emissions mitigation, an important practice that has been implemented and is being promoted at the national level is the use of biogas produced by the anaerobic fermentation of organic materials [38]. This practice is currently used at a limited, local scale.

A selection of CSA practices with high climate-smartness ratings are provided in Table 1. Climate-smartness was rated according to the results of an online survey, in conjunction with a review of literature relevant to the agroecological contexts of Chad.<sup>2</sup>

Climate-smart scores are calculated by evaluating a practice's individual scores along eight dimensions that pertain to the CSA pillars: productivity in terms of yield; adaptation in terms of income, water, soil, and risks; and mitigation in terms of energy, carbon, and nitrogen. A practice can have a negative, positive, or zero impact on a selected CSA indicator, with 10 (+/-) indicating a 100% positive or negative change and 0 indicating no change.

<sup>2</sup> The typical methodology for evaluating climate-smart potential of various adaptive agricultural practices was not possible during this study due to myriad challenges presented by the COVID-19 pandemic and difficult political contexts in Chad.

**Table 1.** Climate smartness ratings for CSA practices in Chad

CSA practice	Region	Predominant farm scale S: small scale M: medium scale L: large scale	Climate smartness	Impact on CSA Pillars
<b>Water management</b>				
Bunds - trapezoid, semi-circle, contour, and water spreading  ++	Sahelian	L	 5.6	<p><b>Productivity</b> Reduced leaching of nutrients off-farm, which boosts productivity; better nutrient use efficiency</p> <p><b>Adaptation</b> Reduced water and wind erosion; better infiltration of water to enhance soil moisture and aquifer recharge</p> <p><b>Mitigation</b> Reduced soil degradation; trapping of soil organic carbon</p> <p><b>Barriers</b> A lack of knowledge about the technique; high labor requirements; challenges to understanding contour lines</p>
Zai Farming/ Half moon  ++	Sahelian	N/A	 5.8	<p><b>Productivity</b> Augmented water availability, which increases yields</p> <p><b>Adaptation</b> Improved soil structure; increased water holding capacity; reduced losses during periods of drought; cessation or reversal of desertification; less wind erosion; protection of seedlings from wind damage</p> <p><b>Mitigation</b> Improved soil quality and structure; trapping of more soil organic carbon</p> <p><b>Barriers</b> Labor-intensive; required application of fertilizer for full effectiveness</p>
Pump and solar irrigation  ++	Soudanian Sahelian	M	 4.8	<p><b>Productivity</b> Reduced pumping costs through the use of solar power; larger crop yields; improved water availability; lower maintenance costs</p> <p><b>Adaptation</b> Access for farmers to ground water in times of drought</p> <p><b>Mitigation</b> Reduced greenhouse gas emissions through the use of solar instead of diesel pumps</p> <p><b>Barriers</b> Water table too deep to access (&gt;60 m in places); high costs of hydraulic equipment; inaccessibility of irrigation equipment</p>



- Yield
- Income
- Water
- Soil
- Risk/Information
- Energy
- CO<sub>2</sub> Carbon
- Nutrient
- Drought
- Pest & Disease
- High temperatures
- Floods
- Salinization
- Heavy rains



CSA practice	Region	Predominant farm scale S: small scale M: medium scale L: large scale	Climate smartness	Impact on CSA Pillars
--------------	--------	---	-------------------	-----------------------

**Water management**

Spreading threshold



Soudanian  
Saharian  
Sahelian



**Productivity**

Water conservation and soil moisture for arable floodplain sites; water retention for better groundwater recharge; increased agricultural production and stronger ecosystems

**Adaptation**

Increased availability of food resources; empowerment of women to dispose of land; increased autonomy for women

**Mitigation**

Contribution to ecological balance; ecosystem restoration; regeneration of plants that capture carbon dioxide; retention of water in plots

**Barriers**

Land problems and sometimes illiteracy in the population



Yield    Income    Water    Soil    Risk/Information    Energy    CO<sub>2</sub> Carbon    Nutrient



Drought



Pest & Disease



High temperatures



Floods



Salinization



Heavy rains

CSA practice	Region	Predominant farm scale S: small scale M: medium scale L: large scale	Climate smartness	Impact on CSA Pillars
--------------	--------	---	-------------------	-----------------------

**Soil management**

Manure and composting



Soudanian  
Sahelian



**Productivity**

Higher yields due to improved nutrient availability; better soil structure and fertility

**Adaptation**

Healthier crops; heightened resilience to pest and disease outbreaks; greater water holding capacity of soils; less soil erosion

**Mitigation**

Increased store of soil organic carbon through the intergration of organic matter into soils; reduced use of inorganic fertilizers and associated greenhouse gas emissions

**Barriers**

High costs for organic fertilizers; unavailability in agricultural regions

Mulching with wooden branches



Soudanian  
Sahelian

N/A



**Productivity**

Improved soil composition; higher yields through improved growing conditions

**Adaptation**

Higher levels of soil moisture in times of drought

**Mitigation**

More organic matter integrated into soils

**Barriers**

Competing use of sorghum and cowpea stalks for fodder and mulch; use of tree branches instead

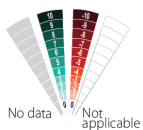

Yield    Income    Water    Soil    Risk/Information    Energy    Carbon    Nutrient



Drought



Pest & Disease



High temperatures



Floods



Salinization



Heavy rains

CSA practice	Region	Predominant farm scale S: small scale M: medium scale L: large scale	Climate smartness	Impact on CSA Pillars
--------------	--------	---	-------------------	-----------------------

**Crop management**

Intercropping  

Soudanian  
Sahelian  
Saharian



**Productivity**

Heightened agricultural productivity; enhanced incomes; reduced labor requirements

**Adaptation**

Diversification of income sources; higher resilience to climate hazards through diversified production; better soil fertility

**Mitigation**

Improved input use efficiency, which reduces greenhouse gas emissions intensity

**Barriers**

Poor knowledge about the correct spacing between crops; farmer-breeder conflict

Crop rotation  

Soudanian  
Sahelian



**Productivity**

Increased farm income; better yields; improved soil fertility

**Adaptation**

Diminished impacts from pest and disease outbreaks

**Barriers**

A lack of information about the practice and its benefits;

Improved, climate-resilient varieties tolerant to droughts, heat, and floods and short-duration varieties



Soudanian  
Sahelian



**Productivity**

Higher yields; augmented farmer incomes

**Adaptation**

Increased resilience to climatic shocks; reduced losses from pest and disease outbreaks

**Mitigation**

Improved input use efficiency, which reduces greenhouse gas emissions intensity

**Barriers**

Limited availability of improved seeds in local markets; high purchase prices for improved seeds; inadequate knowledge about the benefits of improved seeds and the most appropriate varieties; traditional practice of using leftover seed; heightened fertilizer requirements









Yield    Income    Water    Soil    Risk/Information    Energy    Carbon    Nutrient

Drought    Pest & Disease    High temperatures    Floods    Salinization    Heavy rains

CSA practice	Region	Predominant farm scale S: small scale M: medium scale L: large scale	Climate smartness	Impact on CSA Pillars
--------------	--------	---	-------------------	-----------------------

**Livestock and fodder**

<p>Improved fodder varieties of grasses and legumes</p> 	<p>Sahelian Saharian</p>	<p>N/A</p>		<p><b>Productivity</b> Improved feed, which raises livestock productivity and income</p> <p><b>Adaptation</b> Better quantity and quality of feed; promotion of soil and water conservation; less soil erosion when grown in contours</p> <p><b>Mitigation</b> Nitrogen fixation in forage legumes, which reduces the use of inorganic fertilizers; improved grasses that increase carbon sequestration</p> <p><b>Barriers</b> Insufficient availability and high cost of seeds</p>
<p>Feed supplements</p> 	<p>N/A</p>	<p>N/A</p>		<p><b>Productivity</b> Better livestock productivity and income</p> <p><b>Adaptation</b> Increased feed availability, which relieves pressure on fodder resources</p> <p><b>Mitigation</b> Possible reductions in enteric fermentation, depending on the composition and quality of supplements</p> <p><b>Barriers</b> High cost and inadequate availability of feed supplements</p>
<p>Herd mobility and grazing</p> 	<p>Sahelian Saharian</p>	<p>N/A</p>		<p><b>Productivity</b> Heightened productivity of fodder and other crops through fertilization; improved quality, structure, and fertility of soils; avoidance of risky overgrazing</p> <p><b>Adaptation</b> Improved quality, structure, and fertility of soils; avoidance of risky overgrazing; greater biodiversity of herbaceous and woody plants</p> <p><b>Barriers</b> "Conflict between farmers and herders; a lack of regard for rules regulating mobility among transhumance herders; high energy expenditure in search of forage and less time allocated to grazing; forage and water scarcity in the dry season leading to live weight loss</p>

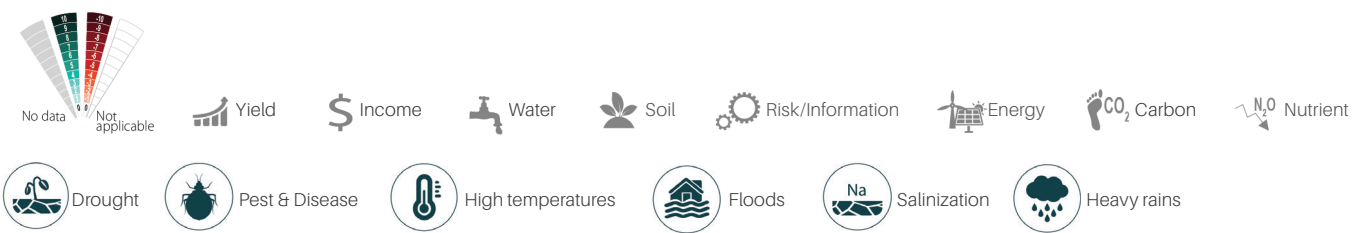

## A case study of water-spreading weirs in Chad<sup>50</sup>



This section presents a case study of water-spreading weirs constructed by non-governmental organizations (NGOs) in Chad (Image 1). The Association for the Promotion of Local Development Initiatives at Ennedi and the Rural Development Program at Wadi Fira, former programs of the Swiss Cooperation Development Directorate, support local populations in improving their living conditions. Together they facilitated the construction of water-spreading weirs to manage and control runoff. Water-spreading weirs are constructed along temporary watercourses, called wadi, that fill with water during the rainy season. They slow the rate of runoff and allow

water to accumulate in basins, creating watering points for livestock and promoting the underground infiltration of water to sustain growing vegetation. Both Ennedi and Wadi Fira are subject to rainfall not exceeding 400 mm per year. Precipitation in 2015 sat between 150-200 mm across Wadi Fira. Dromedary camel, cow, and sheep herding is widespread, as is market gardening, particularly in Wadi Fira.

Given the area's rugged topography, runoff can flow violently, thus contributing to soil degradation. Low infiltration and high runoff are major challenges to the maintenance of agro-pastoral activities. Water-spreading weirs help address these issues. Their smaller size and lower costs differentiate them from conventional dams. They are installed on floors of the wadis, extending across their entire widths. Water-spreading weirs last several years, and cost approximately 20 million Central African Francs (about US\$37,000).

Water-spreading weirs have the following benefits:

- limiting soil degradation and desert progression through the regeneration of vegetation cover
- recharging underground water upstream and downstream of the structures, especially in areas with fragile ecosystems
- making water available for animals and market gardening over a good part of the dry season
- regenerating and fertilizing agricultural land via silt deposition
- facilitating land preparation for market gardening
- improving the success rates of pastoral wells via groundwater recharge
- increasing sustainable herd size; for example, in Doukour, the average number of livestock per family has doubled since implementation
- reducing the burden on women of fetching household water
- improving household living conditions

Water-spreading weirs allow local communities both to adapt to climate hazards and to increase agricultural production, thus serving the main pillars of CSA. Their advantages have been underpinned by a participatory and communal dynamic. Communities contribute money, materials, and local labor to their construction. A contract or collective agreement for the appropriation and management of the works is established by the communities involved.

## Institutions and policies for CSA

Existent institutions and key policies promote CSA initiatives in Chad to encourage and increase agricultural productivity, adapt to climate change, and help reduce GHG emissions. Institutions supporting climate adaptation fall primarily under ministerial departments whose mandates and missions reflect a sustainable development perspective. There are many institutions whose activities revolve around one, two, or three of CSA's adaptation, productivity, and mitigation pillars (Figure 16). Together with the international community, Chad has adopted a series of measures that advance climate change adaptation and mitigation in its territory.

At the national level, adaptation initiatives began with the funding of the National Adaptation Program of Action for Climate Change in 2009. The Ministry of Environment, Water, and Fisheries is at the forefront of generating and promoting climate change policies. The main institutions involved in the development of CSA at the national level are the Ministry of Environment, Water and Fisheries (MEEP); the Ministry of Production, Irrigation, and Agricultural Equipment (MPIEA); and the Ministry of Livestock and Animal Productions (MEPA). The Ministries of the Economy and Development Planning and of Finance and Budget contribute to the mobilization of resources.

Under the MPIEA, the National Agricultural Development Agency (ANADER), the Chadian Institute of Agronomic Research for Development (ITRAD), the National Locust Control Agency, the Plant Protection Directorate, and the Seeds and Plants Directorate facilitate the adoption of CSA practices at the national and local levels. The primary mission of ANADER is promoting agro-sylvo-pastoral and fishery production chains through the popularization of agricultural practices that increase productivity and promote agricultural diversification. ITRAD carries out research on crops, cattle farming, fishery, and socioeconomic questions—including the development and distribution of seed—to expand the dissemination of climate-resistant varieties to farmers in all the agroecological zones. ITRAD also works in collaboration with international research centers, including the Consultative Group for International Agricultural Research (CGIAR), the International Institute of Tropical Agriculture, and AfricaRice. It also works with the Centre for International Cooperation in Agricultural Research, the West and Central African Council for Agricultural Research and Development (CORAF), and the School of Agriculture, Forest, and Food Science.

The Great Green Wall Initiative and the Special Fund for Climate and Environment Protection (FSE), both under the auspices of the MEEP, represent institutional instruments for the implementation of climate change adaptation efforts. The National Meteorology Agency provides weather reports that serve as the basis for early warning systems and climate information services, including final dates for crop sowing, to all agricultural stakeholders. These forecasts are disseminated through community radios stations.

Figure 16. Institutions for CSA in Chad

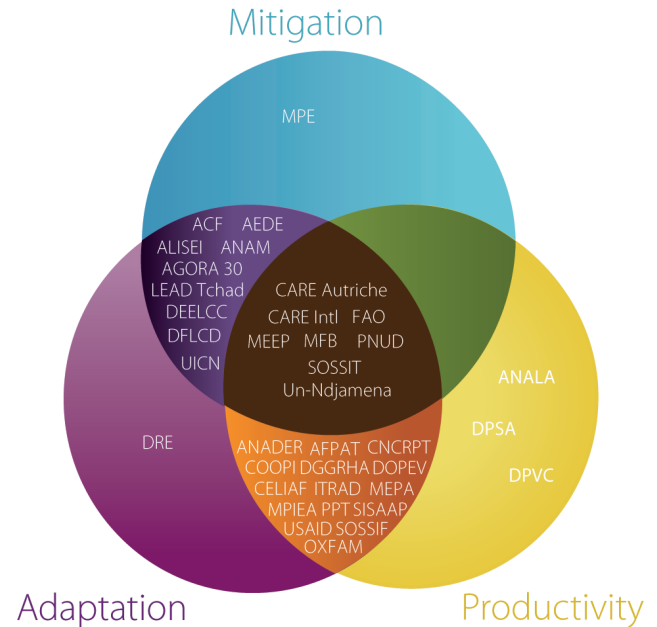

ACF Action Contre la Faim AEDE Agence pour les Energies Domestiques et l'Environnement AFPAT Association des Femmes Peules Autochtones du Tchad AGORA 30 Plateforme AGORA 30 de la résilience du Tchad ALISEI Association for International Cooperation to Development and Humanitarian Aid CANAM Agence Nationale de la Meteorologie ANADER Agence Nationale de developpemnt Rural ANALA Agence Nationale de Lutte Antiacridienne CARE Autriche Cooperative for Assistance and Relief Everywhere Autriche CARE Intl Cooperative for Assistance and Relief Everywhere Intrnational CELIAF Cellule de Liaison et d'Information des Associations Féminines CNCRPT Conseil National de Concertation des Producteurs Ruraux du Tchad COOPI Cooperazione Internazionale DEELCC Direction de l'Education Environnementale et de la Lutte contre les Changements Climatiques DFLCD Direction des Forets et de la lutte contre la Desertification DGGRHA Direction Generale du Génie rural et de l'hydraulique Agricole DOPEV Direction de l'organisation des professionnels de l'élevage et de la vulgarisation DPSA Direction de la Production et des Statistiques Agricoles DPVC Direction de la Protection des Végétaux et du Conditionnement DRE Direction des Ressources en Eau FAO Organisation des Nations Unies pour l'Agriculture Alimentation ITRAD Institut Tchadien de Recherche agronomiques et de Developpement LEAD Tchad Leadership pour l'Environnement et le Développement au Tchad MEEP Ministère de l'Environnement de l'Eau et de la Peche MEPA Ministère de l'Elevage et de la Production Animales MFB Ministère de Finances et du Budget MPE Ministère de Pétrole et de l'Energie MPIEA Ministère de la Production, de l'Irrigation et et des Equipements Agricoles PNUD Programme des Nations Unies pour le Deelopement PPT Plateforme pastorale du Tchad SISAAP Système d'Information sur la Sécurité Alimentaire et des Alertes Précoces SOSSIF SOS Sahel International France SOSSIT SOS Sahel International Tchad UICN Union Internationale pour la Conservation de la Nature Un-Ndjamena Université de Ndjamena, Departement de Géographie USAID United States Agency for International Development

National and international NGOs are also active in supporting the adoption of CSA practices. Many ongoing projects in Chad aim to improve the livelihoods of smallholder farmers and, in light of the crucial links between CSA and food security, some take into account climate risk management practices. For example, the SOS Sahel project is using climate change resistant plants and working on the rehabilitation of land [51]. Additionally, private-sector companies such as Etude, Suivi, Construction et Organisation des Ruraux (ESCOR) Agro and cooperatives such as the Chadian Federation of Seed Producers are active in CSA development.

The government's interest in promoting a multi-sectoral approach to combat climate change is illustrated by the creation of the Agora 30 on Climate Resilience national platform in June 2016. This initiative gathers members of civil society, technical ministries, and development partners to contribute to the dissemination of knowledge and initiatives, and to foster discussion, generate political influence, and share best practices to reinforce Chad's resilience against climatic shocks [38].

United Nations agencies, particularly the United Nations Development Program (UNPD), the World Bank, and the FAO, support the government of Chad in mobilizing resources, executing programs and projects, and assisting in the elaboration of CSA policies.

According to documentary review and information from key actors, CSA does not appear to be explicitly included in political and institutional priorities in Chad. However, priority intervention programs, strategies, and projects are underway that contribute to productivity and climate change adaptation goals. A national climate change strategy (SNLCC) was formulated in 2018. As part of its Nationally Determined Contributions to the Paris Agreement, Chad is committed to strengthening its own climate change resilience and to the global effort to reduce GHG emissions. Its National Development Plan (PND) includes strategic lines of intervention and programming that focus on production supply, decent employment opportunities, the fight against inequality and poverty, natural resource management, and climate change adaptation in accordance with the national environmental policy.

At the operational level, many important plans, programs, and strategies have recently been formulated or are in the process of implementation. These include the National Action Plan for Adaptation to Climate Change (PANA-Chad), the Action Plan for Adaptation to Climate Change and Lake Chad Development (PRESIBALT), and the National Climate Change Strategy. The government promotes resilient agriculture in order to achieve the following benefits:

- To ensure the management and sustainable control of water through micro-dams and irrigation
- To secure agro-sylvo-pastoral and fish productions
- To reverse the degradation of agricultural land through practices such as zai and half-moon pits

- To uphold the sustainable management of pastures by promoting improved fodder varieties
- To slow the degradation of forests and foster optimal, sustained production in a preserved environment
- To manage biodiversity in the long term

Currently, Chad does not have an overarching National Adaptation Plan. However, through the Vision 2030: *The Chad We Want*, which focuses on long-term structural changes to society, governance, and finance, it aims to transform its economy and environment. The National Adaptation Plan will integrate climate adaptation strategies into public policies, planning, and budgeting [52]. Other programs implemented during the last decade include the following:

- The National Desertification Control Program (PAN/LCD)
- Rehabilitating and strengthening socio-ecological systems in the Lake Chad Basin
- Sustainable land management and adaptation to climate change in the Sahel and West Africa (PRGDT)
- The Sustainable Development Program of the Lake Chad Basin (PRODEBALT)
- The National Food Security Program (PNNA)
- The National Rural Sector Investment Program (PNISR)

Chad has a variety of projects aimed at strengthening the resilience of its population in terms of food and nutritional security. The Agro-sylvo-pastoral Orientation (LOAH, 2018) integrates productivity and climate change challenges and offers institutional and operational instruments to support the modernization of the agricultural sector and the development of green jobs. Under this policy, tax exemptions for farm inputs, the establishment of subventions, and the reinforcement of extension activities all contribute to developing and enhancing green value chains. Initiatives promoting new information and communication technologies are also mobilizing public- and private-sector actors for the provision of extension services.

## The Project to Strengthen Climate Resilience and Sustainable Productivity (ProPAD)

in Chad is an innovative national project that covers three provinces: Mandoul, Salamat, and Moyin-Chari. Its objective is to increase productivity and strengthen the climate resilience of agricultural production systems in these areas by promoting the adoption of improved technologies.

The program's total cost is US\$41 million (FCA 22.55 billion), including FCA 1.2 billion from state contributions. The World Bank provides funding that covers most of the remaining budget. The project has a life cycle of five years and involves four components: institutional support for the development of sustainable agriculture and climate resilience; support for the adoption of demand-driven technologies and climate-smart agriculture; emergency response as needed; and coordination, knowledge management, monitoring, evaluation, and learning.

Policies, strategies, and programs that relate to agriculture and climate change are the main facilitators of CSA in Chad. There are gaps and opportunities in policy making at three stages: formulation, when policies are in an initial phase or a consultation process; formalization, when policies are

developed at the national level; and implementation, where visible progress towards the achievement of broader policy objectives can be seen through concrete strategies and action plans (Figure 17).

Figure 17. Policies for CSA in Chad

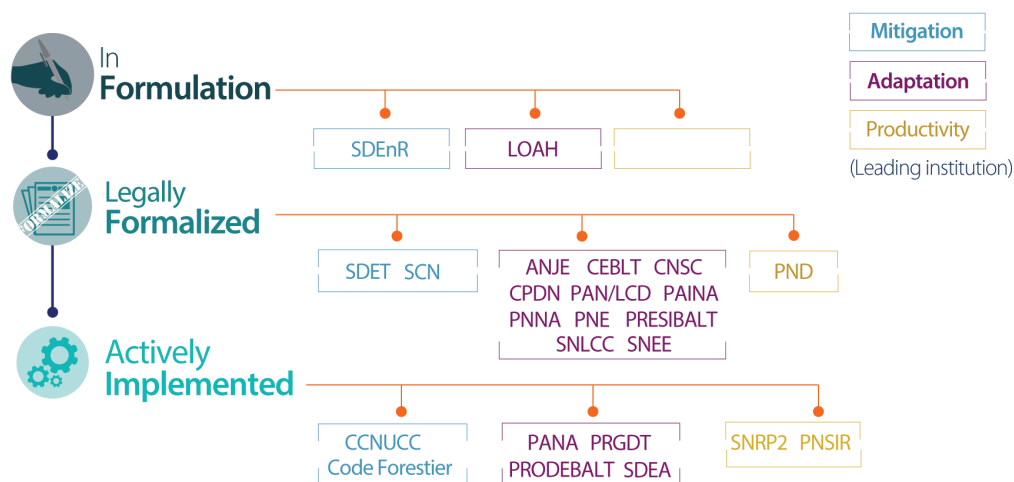

**ANJE** Stratégie Nationale de l'Alimentation du Nourrisson et du Jeune Enfant au Tchad (2017) (Ministère de la Santé Publique)  
**CEBLT** Charte de l'Eau du Bassin du Lac Tchad (2011) (Commission du Bassin du Lac Tchad) **CNI** Communication nationale Initiale du Tchad sur les changements climatiques (2001) (Ministère de l'Environnement, de l'Eau et de la Pêche) **CNSC** Cadre National pour les Services Climatiques du Tchad (2016-2020) (2016) (Ministère de l'Aviation Civile et de la Météorologie Nationale) **CPDN** Contributions Prevues Déterminées au niveau National (2015) (Ministère de l'Environnement, de l'Eau et de la Pêche) **LOAH** Loi d'Orientation Agro- Sylvio- pastorale et Halieutique (2019) (MEEP, MPIEA,MEPA) **PAINA** Plan d'Action Intersectoriel de Nutrition et d'Alimentation 2017-2025 (2017) (Ministère de la Santé Publique) **PAN/LCD** Plan d'Action Nationale de Lutte contre la Désertification (2012) (Ministère de l'Environnement, de l'Eau et de la Pêche) **PANA** Plan d'Action Nationale d'Adaptation (2010) (Ministère de l'Environnement, de l'Eau et de la Pêche) **PNE** Politique Nationale de l'Environnement (2017) (Ministère de l'Environnement, de l'Eau et de la Pêche) **PND** Plan National de Développement 2017-2021 (2017) (Ministère de l'Economie et de la Planificatio du Developpement) **PNNA** Politique Nationale de Nutrition et d'Alimentation (2014) (Ministère de la Santé Publique) **PNSIR** Programme National d'investissement du Secteur Rural (2014) (Ministère de la Production, de l'Irrigation et des Equipement Agricoles) **PRESIBALT** Plan de Développement et d'Adaptation au Changement Climatique du Lac Tchad (2013) (CBLT) **PRGDT** Programme régional de gestion durable des terres et d'adaptation aux changements climatiques au Sahel et en Afrique de l'Ouest (2011) (Comité Inter-Etat de Lute contre la Sécheresse au Sahel) **PRODEBALT** Programme de développement durable du bassin du Lac Tchad (2010) (Commission du Bassin de Lac Tchad) **SCN** Seconde communication nationale du Tchad sur les changements climatiques (2012) (Ministère de l'Environnement, de l'Eau et de la Pêche) **SDEA** Schéma Directeur de l'Eau et de l'Assainissement du Tchad (2003) (Ministère de l'Environnement, de l'Eau et de la Pêche) **SDEnR** Schéma Directeur pour le développement des Energies Renouvelables au Tchad (2018) (Ministère du Pétrole et de l'Energie) **SDET** Schéma Directeur du Secteur de l'Energie au Tchad (2011) (Ministère du Petrole et de l'Energie) **SNEE** Stratégie Nationale de L'Education Environnementale ( 2015-2020) (2015) (Ministère de l'Environnement, de l'Eau et de la Pêche) **SNLCC** Stratégie Nationale de Lutte contre les Changements Climatiques (2017) (Ministère de l'Environnement, de l'Eau et de la Pêche) **SNRP2** Stratégie Nationale pour la Réduction de la Pauvreté (2008) (Ministère de l'Economie et de la Planificatio du Developpement)



## Financing CSA

### National Funding

Funding for CSA comes from sources including public and private institutions and bilateral, decentralized, and multinational cooperative arrangements (Figure 18). The Government of Chad is the main provider of CSA resources through annually allocated sectoral budgets. The creation of special funds by the MEEP helps mobilize resources for development investments. These funds include the National Water Fund and the FSE, both of which were created to generate resources through taxes. However, there is a lack of a systemic mechanisms for evaluating the contributions of dedicated funding for CSA, and private funds remain not well documented.

United Nations agencies, including the FAO, the International Fund for Agricultural Development (IFAD), and UNDP, contribute to the financing of CSA-type interventions across agroecological zones in Chad. IFAD focuses on sustainable agricultural development and strengthening population-level resilience in financing the Adaptation for Smallholder Agriculture Programme, which supports projects that strengthen household resilience [53]. Other United Nations funds, such as the Global Environment Fund, also promote CSA-related initiatives in Chad.

The European Union's 11th European Development Fund, for the period 2014-2020, globally, is endowed with 297 million euros for food security, nutrition, and rural development, and 53 million euros for the sustainable management of natural resources. Support from the European Union has enabled the Alliance Mondiale Contre le Changement Climatique-Chad project [54], which supports renewal energy projects under the mandate of adapting to the effects of climate change.

The World Bank supports CSA adoption throughout Africa; in Chad, its activities are governed by a partnership framework that seeks to increase agricultural productivity and diversify value chains [55]. With its partners, the World Bank in Chad promotes CSA-oriented policies and finances investment programs to develop appropriate technologies [56]. The World Bank also finances the Project to Strengthen Climate Resilience and Sustainable Productivity (ProPAD) project. The African Development Fund (AFD) supports the Chad component of the Integrated Program for Development and Adaptation to Climate Change in the Niger Basin (PIDACC/BN) through a grant to the Niger Basin Authority [57]. AFD has also supported the PASTOR project in Chad since 2015, which aims to improve sustainable use of pastoral resources by considering the needs of local populations in pastoral and agro-pastoral zones and developing their resilience capacity.

Other regional organizations, such as Niger Basin Authority and the Lake Chad Basin Commission, mobilize resources from bilateral, decentralized, and multilateral cooperative sources [58]. Other national NGOs, including ESCOR Agro, FENOPS Tchad, and Lead Tchad, as well as international organizations like SOS Sahel, provide funding for CSA

efforts. The Swiss Agency for Development and Cooperation supports projects aimed at the adaptation and development of sustainable agriculture and watershed management.

**Figure 18. Financing opportunities for CSA in Chad**

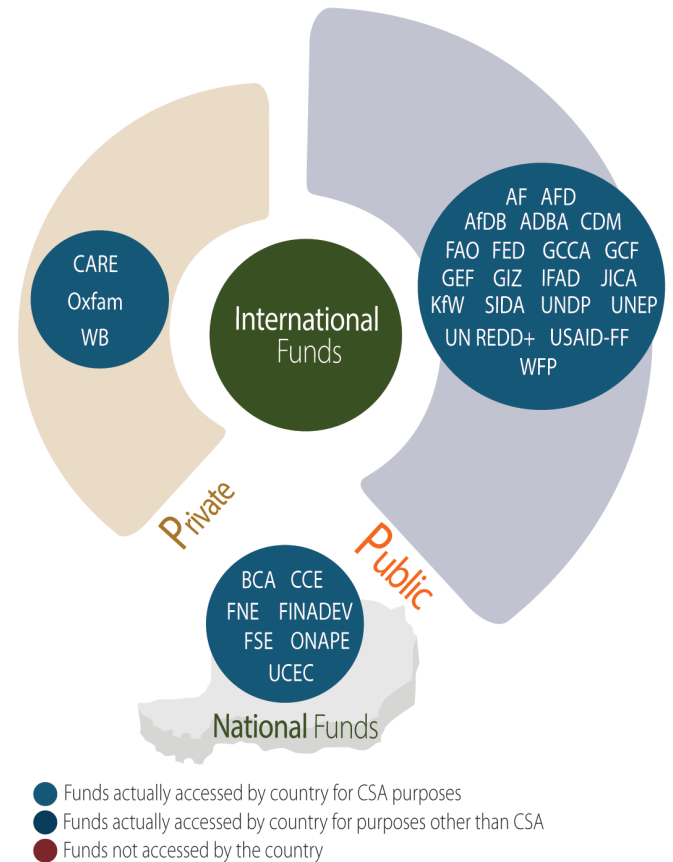

ADBA Arabic Development Bank for Africa AF Adaptation Fund AFD French Development Agency AfDB African Development Bank BCA Banque de Crédit Agricole CARE Cooperative for Assistance and Relief Everywhere CCE Coopérative de Crédit et Epargne (CCE) CDM Clean Development Mechanism FAO Food and Agriculture Organization of the United Nations FED European Union Development Fund FINADEV Financial Development FNE Fond National de l'Eau FSE Fond Spécial en Faveur de l'Environnement GCCA Global Climate Change Alliance GCF Green Climate Fund GEF Global Environment Facility GIZ German Society for International Cooperation IDB Islamic Development Bank IFAD International Fund for Agricultural Development JICA Japan International Cooperation Agency KfW German Development Bank International Climate Initiative ONAPE Office National pour la Promotion de l'Emploi SIDA Swedish International Development Cooperation Agency UCEC Union des Caisses d'Epargne et de Crédit UNDP United Nations Development Programme UNEP United Nations Environmental Programme UN REDD United Nations Programme on Reducing Emissions from Deforestation and Forest Degradation USAID-FF United States Agency for International Development – Feed the Future WB The World Bank Group WFP World Food Programme

## Potential Funding

Funding exists to which Chad does not currently have access, but which could be released through establishing donor relationships or meeting eligibility criteria. For example, Chad is eligible for financing from the Green Climate Fund. However, the lengthy application process creates a barrier to access. Due to such structural constraints, these funds may best reach Chad through funding mobilized by its technical and financial partners.

Chad could also secure loans from multilateral financial institutions such as the Asian Development Bank, the Arab Bank for Economic Development in Africa, the World Bank, the Islamic Development Bank, and the European Union. Other Arabic nations and bilateral cooperation partnerships with countries such as Germany, China, France, the Netherlands, and Switzerland might also be sources of funding. This financing could be used for strengthening the institutional, organizational, and operational capacities of institutions likely to attract additional funds through their respective missions [59]. The integration of climate change into sectoral and national policies, the coherence of national policies, and the creation of the National Adaptation Plan could also help generate funding.

- Training stakeholders and reinforcing their capacity for adaptation and mitigation mechanisms to respond to climate change
- Popularizing CSA practices and technologies at all levels
- Developing a detailed, reliable, available, and coherent agricultural database to facilitate the formulation, management, and monitoring of the agricultural sector's development plans and projects

Chad's current policy lays a good foundation for launching coordinated efforts to bring existing and new CSA technologies to scale. Early successes will pave the way for further funding opportunities and the engagement of the private sector in building out a climate-smart Chadian agricultural sector.

## Summary and Perspectives

Chad has made enormous efforts to establish a favorable environment for the creation and support of CSA initiatives, most notably with regards to climate change-oriented policies such as the Nationally Determined Contributions, the National Adaptation Plan, the National Investment Plan for the Rural Sector, the National Livestock Development Plan, and the Five-Year Agricultural Development Plan. These initiatives contribute to the development of resilient agro-sylvo-pastoral production systems in Chad by reinforcing the political, institutional, and operational framework in matters related to climate change. The country also benefits from international funding opportunities for institutional, organizational, and operational capacity-building activities that are likely to attract additional funding for the adaptation and mitigation of climate change effects.

Chad's National Climate Change Strategy prioritizes reinforcing the resilience of agro-sylvo-pastoral and water production systems through climate-smart practices to shrink the negative impacts of climate change and enhance the resistance of communities and the environment [36]. Several major opportunities remain for ensuring the adoption of CSA on a larger scale in Chad, including:

- Considering the current difficulties to integrate adaptation and mitigation of climate change in policies, strategies, and development plans at the national, sectoral, and local levels
- Raising awareness, sharing information, and providing education about the challenges, complexities, and opportunities linked to climate change

## Works cited

- [1] **FAO. 2010.** Agriculture "Climate-Smart". Politiques, pratiques et financement pour la sécurité alimentaire, l'adaptation et l'atténuation. Rome : Organisation des Nations Unies pour l'alimentation et l'agriculture (FAO).
- [2] **FAO. 2013.** Manuel de référence sur l'agriculture intelligente face au climat. Rome : FAO.
- [3] **World Bank. 2019.** World Development Indicators. Available at: <https://data.worldbank.org/indicator>
- [4] **Perspective Agricole. 2021.** Available at: <https://perspective.usherbrooke.ca/bilan/servlet>
- [5] **FAO. 2020.** FAOSTAT. Available at: <http://www.fao.org/faostat/en/#data/TP>
- [6] **FAO. 2018.** Profil National Genre des Secteurs de l'Agriculture et du Développement Rural TCHAD. p112
- [7] **Jean Perre Guengant. 2013.** Population développement et dividende démographique au Tchad. Available at [https://horizon.documentation.ird.fr/exl-doc/pleins\\_textes/divers13-06/010057789.pdf](https://horizon.documentation.ird.fr/exl-doc/pleins_textes/divers13-06/010057789.pdf)
- [8] **UNPD. 2018.** Human Development Reports. Available at: <http://hdr.undp.org/en/data#>
- [9] **UNICEF. 2019.** Access to basic needs. Available at: <https://data.unicef.org/topic/water-and-sanitation/drinking-water/>
- [10] **TCHAD INFO. 2019.** Tchad: 100 hectares de terre cultivables offerts aux femmes rurales du Mayo Kebbi Ouest. Available at: <https://tchadinfos.com/politique/tchad-100-hectares-de-terre-cultivables-offerts-aux-femmes-rurales-du-mayo-kebbi-ouest/>
- [11] **FAO. 2016.** Available at: <http://www.fao.org/faostat/en/#data/RL>
- [12] **MPIEA. 2019.** Analyse de l'efficacité des politiques en matière de sécurité alimentaire et nutritionnelle, et d'agricultures durable
- [13] **FAO. 2021.** AQUASTAT. Available at <http://www.fao.org/aquastat/statistics/query/results.html>
- [14] **République du Tchad. 2010.** Programme National de Sécurité Alimentaire (2011-2015).
- [15] **République du Tchad. 2014.** Priorités Résilience Pays (PRT), N'Djamena, Tchad.
- [16] **FAO. 2018.** Recensement Général de l'Elevage au Tchad : Publication des résultats. Available at <http://www.fao.org/africa/news/detail-news/en/c/1128900/>
- [17] **République du Tchad. 2017.** FAIM ZERO. Rapport de l'examen stratégique national Faim Zéro de la République du Tchad.
- [18] **MEPA, 2017.** Plan National de Développement de L'Élevage, PNDE 2 : 2017-2021.
- [19] **BM/Tchad. 2011.** Revue documentaire : potentialités et contraintes.
- [20] **République du Tchad. 2014.** Plan National du Secteur Rural au Tchad 2014-2020.
- [20] **AFD. 2011.** Note prospective sur les enjeux du développement rural au Tchad, N'Djamena, Tchad.
- [21] **INSEED. 2011.** Troisième Enquête sur la Consommation et le Secteur Informel au Tchad (ECOSIT3). Emploi au Tchad en 2011, N'Djaména.
- [22] **FAO. 2019.** FAO/INFOODS Food Composition Databases. Available at <http://www.fao.org/infoods/infoods/tables-and-databases/faoinfoods-databases/en/>
- [23] **FAO. 2019.** Economic indicators. Available at: <http://faostat3.fao.org/download/Q/QV/E>
- [24] **FAO. 2019.** Nutrition quality indicators. Available at: <http://www.fao.org/faostat/en/#data/CL>
- [25] **République du Tchad. 2018.** Document du Projet PROPAD.
- [26] **AFDB. 2018.** Projet d'études pour l'aménagement de 135000 ha de perimetres irrigues. Rapport d'évaluation. Available at [https://www.afdb.org/fileadmin/uploads/afdb/Documents/Project-and-Operations/TCHAD\\_-\\_Approuve%CC%81\\_Projet\\_d\\_e%CC%81tude\\_pour\\_l\\_ame%CC%81ngement\\_de\\_135\\_000\\_ha\\_de\\_pe%CC%81rime%CC%80tres\\_irrigues\\_.pdf](https://www.afdb.org/fileadmin/uploads/afdb/Documents/Project-and-Operations/TCHAD_-_Approuve%CC%81_Projet_d_e%CC%81tude_pour_l_ame%CC%81ngement_de_135_000_ha_de_pe%CC%81rime%CC%80tres_irrigues_.pdf)
- [27] **FAO.2019.** Remise officielle du document de la Stratégie Nationale de Mécanisation Agricole au Tchad. Available at <http://www.fao.org/tchad/actualites/detail-events/en/c/1194012/>
- [28] **Economist Intelligence Unit. 2020.** Global Food Security Index. Available at <https://foodsecurityindex.eiu.com/Country/Details#Chad>
- [29] **Global Hunger Index. 2020.** Available at <https://www.globalhungerindex.org/chad.html>
- [30] **PAM Tchad. 2017.** Analyse Intégrée du Contexte (AIC). Partie I : Rapport Technique. Available at <https://geonode.wfp.org/maps/8895>
- [31] **République du Tchad. 2019.** Enquête nationale de nutrition. Available at [https://www.humanitarianresponse.info/sites/www.humanitarianresponse.info/files/documents/files/rapport\\_final\\_enquete\\_smart\\_27112019.pdf](https://www.humanitarianresponse.info/sites/www.humanitarianresponse.info/files/documents/files/rapport_final_enquete_smart_27112019.pdf)

- [32] **PAM. 2019. FAIM ZÉRO.** Rapport de l'examen stratégique national Faim Zéro de la République du Tchad. Available at <https://www.wfp.org/publications/chad-strategic-review>
- [33] **World Bank. 2021. CO2 emissions data.** Available at <https://data.worldbank.org/indicator/EN.ATM.CO2E.PC>
- [34] **République du Tchad. 2015.** Contribution Prévue Déterminée au niveau National (CPDN) de la République du Tchad. Available at <https://www4.unfccc.int/sites/ndcstaging/PublishedDocuments/Chad%20First/CPDN%20TCHAD%20Version%20officielle%2028%20sept%202015.pdf>
- [35] **PNUD et République du Tchad. 2012.** Cadre d'accélération des OMD. Sécurité alimentaire et nutritionnelle. N'djamena. Tchad [36] Logistics Capacity Assessment. 2020. Chad Road Network data. Available at <https://dlca.logcluster.org/display/public/DLCA/2.3+Chad+Road+Network>
- [37] **Abdoulaye Bedoum, Clobite Bouka Biona, Bell Jean Pierre, Issak Adoum, Robert Mbiake & Laohoté Baohoutou. 2017.** Évolution des indices des extrêmes climatiques en République du Tchad de 1960 à 2008, *Atmosphere-Ocean*, 55:1, 42-56, DOI: 10.1080/07055900.2016.1268995
- [38] **République du Tchad. 2017.** Stratégie Nationale de Lutte contre les Changements Climatiques au Tchad (SNLCC). Available at <http://extwprlegs1.fao.org/docs/pdf/Cha186306.pdf>
- [39] **Collins M ; Knutti R ; Arblaster J ; Dufresne JL ; Fichet T ; Friedlingstein P ; Gao X ; Gutowski WJ ; Johns T ; Krinner G ; Shongwe M ; Tebaldi C ; Weaver AJ ; Wehner M. 2013.** Changement climatique à long terme : Projections, engagements et irréversibilité. Dans : *Changement climatique. La base des sciences physiques. Contribution du groupe de travail I au cinquième rapport d'évaluation du Groupe d'experts intergouvernemental sur l'évolution du climat.* Stocker TF ; Qin D ; Plattner GK ; Tignor M ; Allen SK ; Boschung J ; Nauels A ; Xia Y ; Bex V ; Midgley PM. (eds.). Cambridge University Press, Cambridge, Royaume-Uni et New York, NY, États-Unis. p. 1029-1036. DOI : 10.1017/CBO9781107415324.024
- [40] **République du Tchad. 2009.** Plan d'Action National pour l'Adaptation aux changements climatiques (PANA-Tchad). Available at <http://extwprlegs1.fao.org/docs/pdf/cha146837.pdf>
- [41] **“Deutsche Gesellschaft für Internationale Zusammenarbeit (GIZ) GmbH. 2012.** Bonnes pratiques de CES/DRS. Contribution à l'adaptation au changement climatique et à la résilience des producteurs. Les expériences de quelques projets au Sahel. Bonn, Germany. 60p. Available at [https://reca-niger.org/IMG/pdf/Bonnes\\_pratiques-CES-DRS-GIZ.pdf](https://reca-niger.org/IMG/pdf/Bonnes_pratiques-CES-DRS-GIZ.pdf)
- [42] **UIICN. 2018.** Projet : amélioration de l'information, éducation et communication des populations rurales et périurbaines à l'adaptation aux changements climatiques. Capitalisation des bonnes pratiques d'adaptation au changement climatique dans le secteur de l'agriculture, l'élevage et de la pêche au Tchad, TCHAD. 48p.
- [43] **USAID. 2014.** Agricultural adaptation to climate change in the Sahel, Profiles of agricultural management practices. Available at: [https://www.climatelinks.org/sites/default/files/asset/document/AGR%2002-03%20AG%20Management%20Practices\\_CLEARED.pdf](https://www.climatelinks.org/sites/default/files/asset/document/AGR%2002-03%20AG%20Management%20Practices_CLEARED.pdf)
- [44] **Sarr, B., Atta, S., Ly, M., Salack, S., Ourback, T., Subsol, S., & Georges, D. A. 2015.** Adapting to climate variability and change in smallholder farming communities: A case study from Burkina Faso, Chad and Niger (CVADAPT). *Journal of Agricultural Extension and Rural Development*, 7(1), 16-27.
- [45] **WOCAT. 2021.** WOCAT SLM database. Available at [https://qcat.wocat.net/en/wocat/technologies/view/technologies\\_1536/](https://qcat.wocat.net/en/wocat/technologies/view/technologies_1536/)
- [46] **CIAT; ICRISAT; BFS/USAID. 2020.** Climate-Smart Agriculture in Niger. CSA Country Profiles for Africa Series. International Center for Tropical Agriculture (CIAT); International Crops Research Institute for the Semi-Arid Tropics (ICRISAT); Bureau for Food Security, United States Agency for International Development (BFS/ USAID); 28p.
- [47] **CIAT, ICRISAT, BFS/USAID. 2020.** Climate-Smart Agriculture in Mali. CSA Country Profiles for Africa Series. International Center for Tropical Agriculture (CIAT); Bureau for Food Security, United States Agency for International Development (BFS/USAID), Washington, D.C. 25 p.
- [48] **CIAT; BFS/USAID. 2016.** Agriculture intelligente face au climat au Sénégal. Série de profils pays de l'AIC pour l'Afrique. Centre International d'Agriculture Tropicale (CIAT); Bureau pour la sécurité alimentaire, Agence américaine pour le développement international (BFS/USAID), Washington, D.C. 20 p.
- [49] **UKAID. 2014.** Adapting to the Sahel's changing climate: Local approaches (P50). Available at: <https://www.crs.org/sites/default/files/tools-research/adapting-to-the-sahels-changing-climate.pdf>
- [50] **DDC. 2015.** Fiche de projet. Gestion Des Eaux De Ruissellement Dans Le Tchad Sahélien.
- [51] **SOS Sahel. 2020.** <https://sossahel.org/Publication/>
- [52] **PNUD. 2017.** Plan National d'Adaptation du Tchad aux Changements Climatiques. Available at <https://www.td.undp.org/content/chad/fr/home/projects/PNA.html>
- [53] **IFAD. 2013.** Projet d'Amélioration de la Résilience des Systèmes Agricoles au Tchad (PARSAT).
- [54] **Alliance Mondiale Contre le Changement Climatique (AMCC). 2018.** Available at <https://www.gcca.eu/fr>

[55] **World Bank Group. 2015.** Country partnership framework for the republic of Chad for the period FY16-20

[56] **Braimoh, A. 2018.** Climate-smart agriculture: Lessons from Africa, for the world. Available at <https://blogs.worldbank.org/nasikiliza/climate-smart-agriculture-lessons-from-africa-for-the-world>

[57] **AFDB. 2020.** Programme Intégré de Développement et d'Adaptation au Changement Climatique dans le Bassin du Niger (PIDACC/BN) Composante Tchad.

[58] **Commission du Bassin du Lac Tchad. 2020.** Available at <http://cblt.org/>

[59] **UNCTAD. 2019.** Examen de la politique d'investissement, Tchad. Available at [https://unctad.org/system/files/official-document/diaepcb2019d1\\_fr.pdf](https://unctad.org/system/files/official-document/diaepcb2019d1_fr.pdf)

---

This publication is the result of a collaboration between the Alliance of Bioversity International and the International Center for Tropical Agriculture (CIAT) - lead center of the CGIAR research program on Climate Change, Agriculture and Food Security (CCAFS) - and the International Crops Research Institute for the Semi-Arid Tropics to identify country-specific baselines on CSA in Chad. The document complements the series of CSA profiles developed between 2014 and 2015 by CIAT, CCAFS, and the World Bank for countries in Latin America, Asia, and Africa. The document has been prepared under the direction of Stephanie Jaquet (The Alliance), Prosper Houessionon (ICRISAT/CCAFS), Godefroy Grosjean (The Alliance), Evan Girvetz (The Alliance), Robert Zougmore (ICRISAT/CCAFS). It is based on a methodology prepared by CIAT, the World Bank, and the Center for Research and Higher Education in Tropical Agriculture in 2014 and revisited in 2015 by Andreea Nowak, Caitlin Corner-Dolloff, Miguel Lizarazo, Andy Jarvis, Evan Girvetz, Jennifer Twyman, Julian Ramirez, Carlos Navarro, Jaime Tarapues (CIAT/CCAFS), Charles Spillane, Colm Duffy, and Una Murray (University of Galway).

Main authors: Stephanie Jaquet (the Alliance), Prosper Houessionon (ICRISAT/CCAFS), Bianpambe Patallet (independent consultant) and Lydie Beassemda (independent consultant), James Giles (The Alliance), Carlos Gonzales (The Alliance), Mary Otieno (The Alliance) and Ivy Kinyua (The Alliance).

Translation and copyediting: Megan Mayzelle, Katiana Bougouma, Isabelle Le Marois, Annalese Duprey, Stephanie Pentz, Diogo Rodrigue

Original figures, graphics, design, and layout: Fernanda Rubiano (independent consultant), CIAT

Correct reference: CIAT; ICRISAT ; FAO; World Bank 2021. Climate-Smart Agriculture in Chad. CSA Country Profiles for Africa Series. The Alliance of Bioversity International and the International Center for Tropical Agriculture (CIAT); the International Crops Research Institute for the Semi-Arid Tropics; Food and Agriculture Organization of the United Nations (FAO) and World Bank, Washington, D.C. 28 p.

## Acknowledgement

Funding for the research work in this CSA country profile for Chad was provided by the World Bank and the Food and Agriculture Organization of the United Nations (FAO).

The CSA country profile was prepared under the leadership and guidance of Ziva Razafintsalama (World Bank), Nkulumo Zinyengere (World Bank), Tobias Baedeker (World Bank) and Albert Nikiema (FAO).

This document benefited from the comments of: Marie-Ange Mpambara (WB).